



*Album of Standard Design Solutions for
Engineering Protection (ASDS)*

Saint-Petersburg



GEOIZOL
group of companies

GEOIZOL Group is the leader of Russian building industry in engineering, construction and restoration sector. The origin of the company dates back to 1995. Today GEOIZOL is a multi-specialized incorporating engineering and construction companies, machine building plant and mechanization department.

More than 1500 staff members are employed by the group of companies.



GEOIZOL

Construction of underground and transport objects, reconstruction of cultural heritage sites, engineering protection of territories, geotechnical and hydraulic engineering works, complex services of building structural survey, geotechnical monitoring, static and plate loading soil tests.

Krummelhaus Business Center 12, Bolshaya Posadskaya Ul., St.Petersburg, Russia, 197046

Tel: +7 812 337 53 13, Fax: +7 812 337 53 10 E-mail: info@geoizol.ru

www.geoizol.ru



ГЕОИЗОЛ
проект

Wide range of design services: engineering protection of territories, of all types of foundations, geotechnical feasibility of constructions and design of retaining wall and evaluation of the impact of new construction.

Krummelhaus Business Center 12, Bolshaya Posadskaya Ul., St.Petersburg, Russia, 197046

Tel: +7 812 416 30 28, E-mail: geoizolproject@geoizol.ru

geoizolproject.ru



Pushkin Machine Building plant

Manufacture and supplies of GEOIZOL-MP anchoring systems, drilling machinery, mechanical units, construction metal structures, metal structures for marine and general application

117, Novoderevenskaya Ul., Pushkin, St.Petersburg, Russia, 196600

Tel: +7 812 640 79 95, Fax: +7 812 470 19 51 E-mail: ipmz@geoizol.ru

www.pmzspb.ru



GEOIZOL
PGS

Waterproofing subsurfaces of buildings and structures under construction and at the operational stage. Krummelhaus Business Center 12, Bolshaya Posadskaya Ul., St.Petersburg, Russia, 197046

Tel: +7 812 337 53 16 Fax: +7 812 337 53 10 E-mail: ipgs@geoizol.ru

www.geoizol.ru



УМ ГЕОИЗОЛ

Construction machinery and special equipment.

17, Novoderevenskaya Ul., Pushkin, St.Petersburg, Russia, 196600

Tel: +7 812 640 79 93, E-mail: [ium@geoizol.ru](mailto:iум@geoizol.ru)

www.pmzspb.ru



Album of Standard Design Solutions for Engineering Protection (ASDS) is a unique document compiled by GEOIZOL Project experts to accumulate and structure the most effective experience of technical decisions. Each solution for engineering protection in the Album is provided with all the range of the used materials.

Being the first to implement the solutions on a grand scale in Russia, the experts of GEOIZOL Project developed the technology and theoretically underpinned feasibility evaluation of each solution, adjusted them to meet current norms, gained State Expertise approval for all the projects and executed them on a large scale in frames of GEOIZOL Group.

The technical solutions listed in the Album have been implemented for engineering protection of the slopes and anchoring retaining walls at the following objects of the Olympic infrastructure in Krasnaya Polyana area (Sochi):

- mountaintop resort area of OAO "Gazprom", including cable ways, ski slopes, objects of engineering and transport infrastructure (design, survey works and construction);*
- combined complex for holding cross-country skiing and biathlon competitions, mountain Olympic village (1100 guests), access road, Psekhako Ridge (design, survey works and construction);*
- mountain climatic resort "Alpika Service", including cable ways, ski slopes, objects of engineering and transport infrastructure (design, survey works and construction).*

<i>Content of the album</i>		
<i>№</i>	<i>Content</i>	<i>page №</i>
	<i>Content</i>	<i>1</i>
<i>1</i>	<i>Landslide protection</i>	<i>2</i>
<i>1.1</i>	<i>Piled retaining wall</i>	<i>3</i>
<i>1.2</i>	<i>Piled retaining wall on a slope</i>	<i>4</i>
<i>1.3</i>	<i>Nail strengthening of a slope</i>	<i>5</i>
<i>1.4</i>	<i>Sheetpile retaining wall</i>	<i>6</i>
<i>1.5</i>	<i>Retaining wall on artificial foundation bed</i>	<i>7</i>
<i>1.6</i>	<i>Retaining wall on natural foundation bed</i>	<i>8</i>
<i>1.7</i>	<i>Reinforced retaining wall (type 1)</i>	<i>9</i>
<i>1.8</i>	<i>Gabion retaining wall</i>	<i>10</i>
<i>1.9</i>	<i>Reinforced retaining wall (type 2)</i>	<i>11</i>
<i>1.10</i>	<i>Anchorage with pressure plates</i>	<i>12</i>
<i>1.11</i>	<i>Slope shotcreting</i>	<i>13</i>
<i>2</i>	<i>Erosion protection</i>	<i>14</i>
<i>2.1</i>	<i>Erosion protection</i>	<i>15</i>
<i>3</i>	<i>Water disposal</i>	<i>16</i>
<i>3.1</i>	<i>Drainage</i>	<i>17</i>
<i>3.2</i>	<i>Culvert</i>	<i>18</i>
<i>4</i>	<i>Rockfall protection, mudslide protection, etc.</i>	<i>19</i>
<i>4.1</i>	<i>Rockfall protection barrier</i>	<i>20</i>
<i>4.2</i>	<i>Rockfall protection curtain</i>	<i>21</i>
<i>4.3</i>	<i>Rockfall protection dam</i>	<i>22</i>
<i>4.4</i>	<i>Rockfall protection gallery</i>	<i>23</i>
<i>4.5</i>	<i>Mudslide protection barrier</i>	<i>24</i>
<i>4.6</i>	<i>Shotcreting of a rock mass</i>	<i>25</i>
<i>4.7</i>	<i>Debris flow channel of closed type</i>	<i>26</i>
<i>4.8</i>	<i>Debris flow channel of open type</i>	<i>27</i>
<i>5</i>	<i>Strengthening soft and specific grounds</i>	<i>28</i>
<i>5.1</i>	<i>Grout-injected piles on flexible grillage</i>	<i>29</i>
<i>5.2</i>	<i>Cavern filling</i>	<i>30</i>
<i>5.3</i>	<i>Soil reinforcement, cavern-related mitigation</i>	<i>31</i>
<i>5.4</i>	<i>Replacement of the weak soil</i>	<i>32</i>

<i>5.5</i>	<i>Ground improvement by means of stone columns</i>	<i>33</i>
<i>5.6</i>	<i>Stabilizing soil by binding agent</i>	<i>34</i>
<i>6</i>	<i>Permafrost grounds protection</i>	<i>35</i>
<i>6.1</i>	<i>Thermal stabilizing</i>	<i>36</i>
<i>7</i>	<i>Avalanche protection</i>	<i>37</i>
<i>7.1</i>	<i>Massive avalanche-breaker</i>	<i>38</i>
<i>7.2</i>	<i>Flexible snow bridges</i>	<i>39</i>
<i>7.3</i>	<i>Snow umbrellas</i>	<i>40</i>
<i>7.4</i>	<i>Snow blowing constructions</i>	<i>41</i>
<i>8</i>	<i>Bank stabilization</i>	<i>42</i>
<i>8.1</i>	<i>Bank stabilization of impoundments</i>	<i>43</i>
<i>8.2</i>	<i>Sheet piling wall</i>	<i>44</i>
<i>8.3</i>	<i>Flexible wave canceling structure</i>	<i>45</i>
<i>8.4</i>	<i>Rigid wave canceling structure</i>	<i>46</i>
<i>9</i>	<i>Protecting of the utilities system</i>	<i>47</i>
<i>9.1</i>	<i>Protecting of the utilities system</i>	<i>48</i>

Section 1
Landslide protection

General view

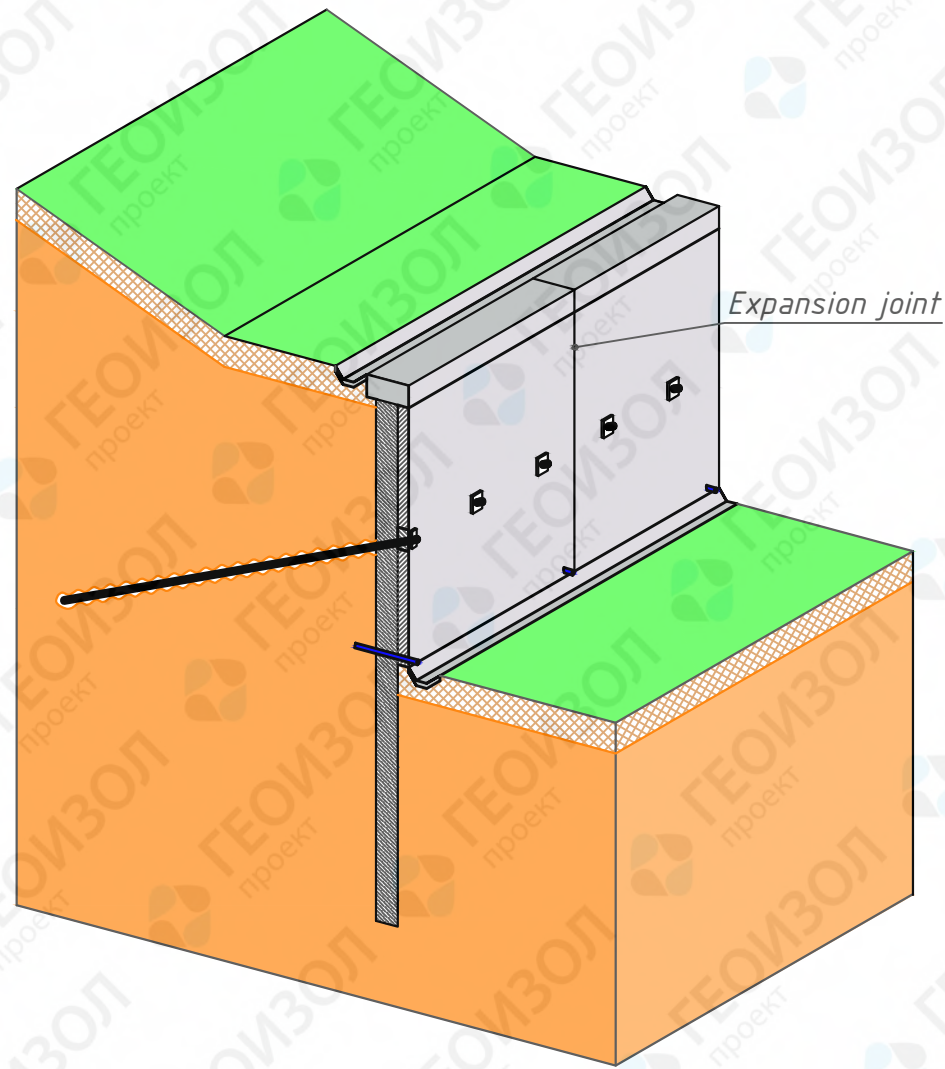

Sectional view

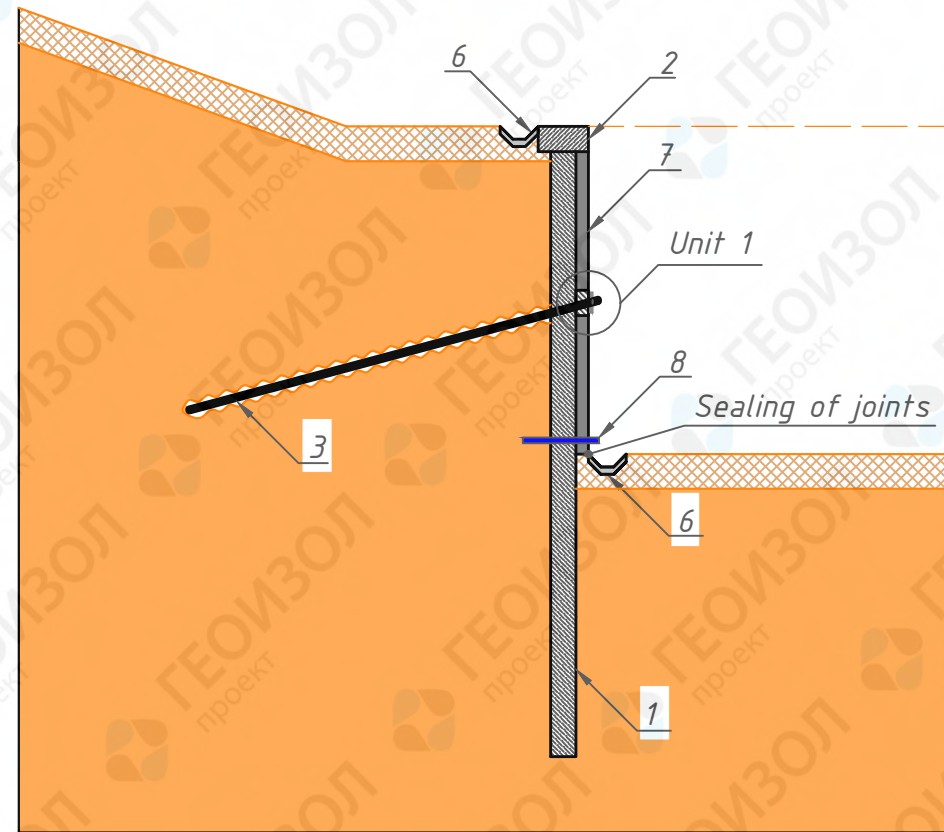

Unit 1

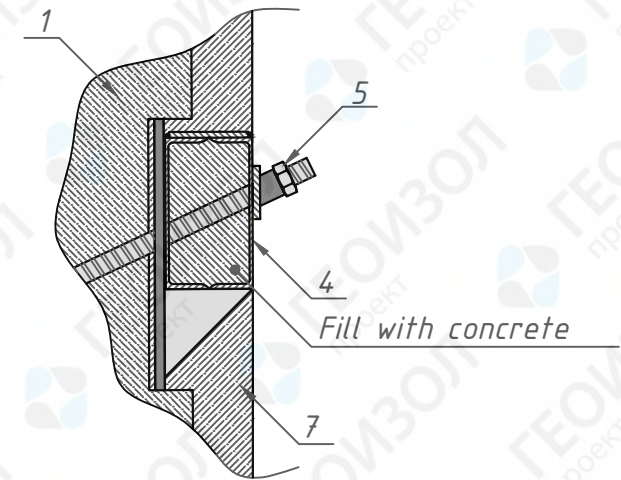

№	Nomination
1	Piled wall
2	Framing beam
3	Ground anchor
4	Distributing beam
5	Set of anchor rod holder
6	Water gutter
7	Curtain wall
8	Drainage pipe

Purpose:

- To strengthen landslide hazard slopes with topographical changes.

Operation concept:

Piles installation is followed by soil cutting. Ground anchors transmit retention forces to the distributing beam and enhance fixation of the retaining wall into the body of the slope. The curtain wall is installed in order to prevent ground spilling into the cavities between piles. The piling wall allows to execute terrain redevelopment and to prepare the surface for the objects construction.

Unique features of the standard design solution:

- Enables construction of objects on different levels;
- Allows compact built-up solutions for challenging terrain;
- Provides new opportunities for difficult terrains redevelopment;
- Simplifies construction methods and operation of the new nearby objects;
- Aesthetically and architecturally balanced type of the ready object.

Examples of the existing objects



Standard design solutions for engineering protection

Section 1	Landslide protection	
Subsection 1	Piled retaining wall	

General view

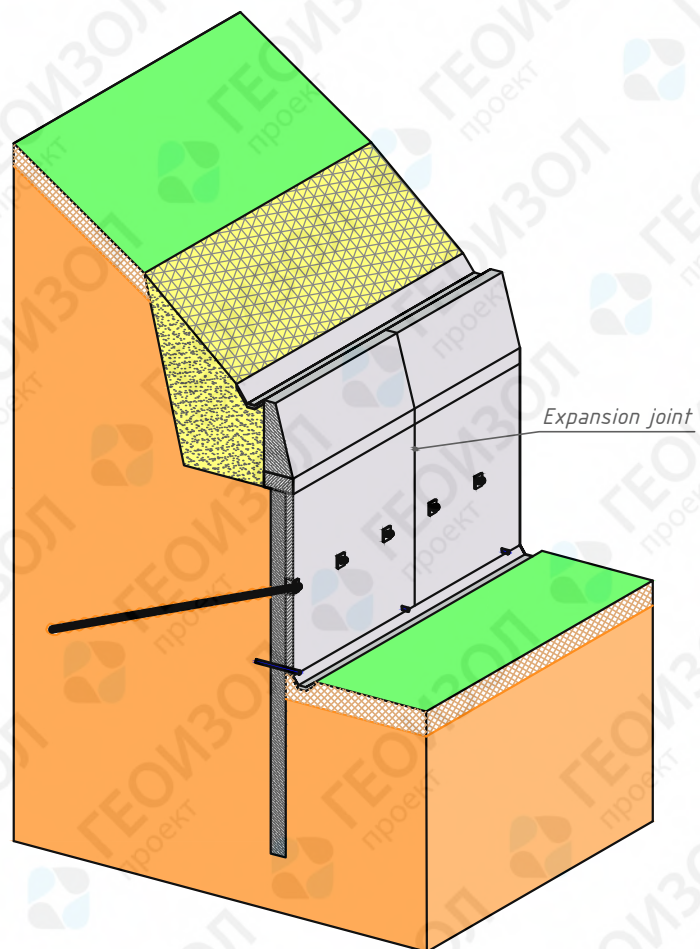

Sectional view

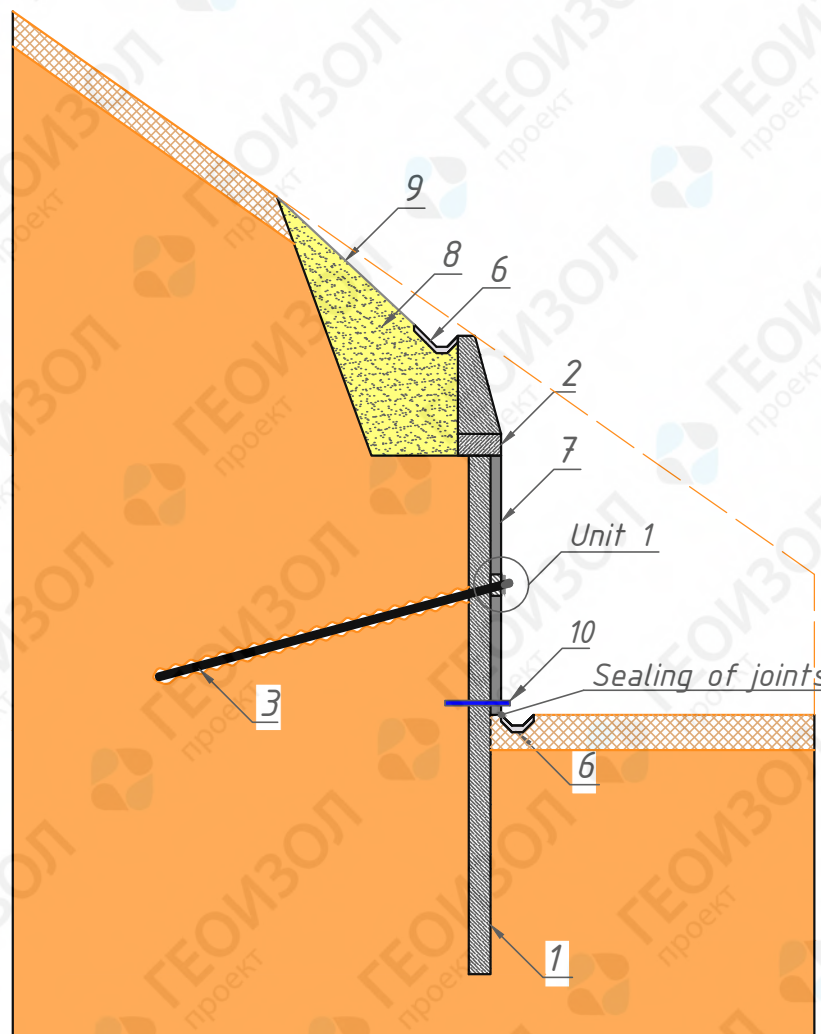

Unit 1

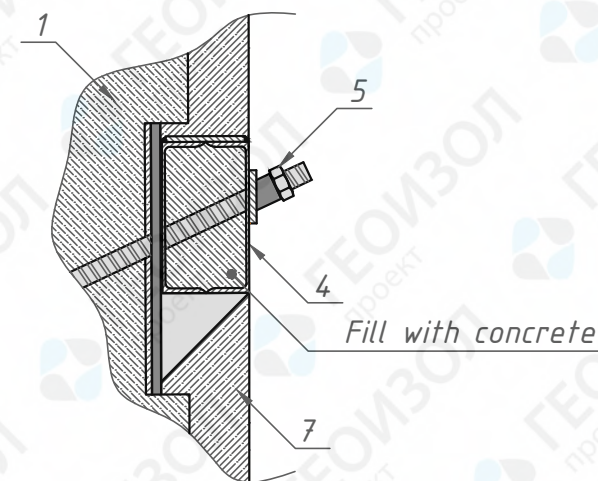

№	Nomination
1	Piled wall
2	Framing beam
3	Ground anchor
4	Distributing beam
5	Set of anchor rod holder
6	Water gutter
7	Curtain wall
8	Backfill
9	Erosion protection
10	Drainage pipe

Examples of the existing objects.



Purpose:

- To strengthen landslide hazard slopes with topographical changes;
- Erosion protection.

Operation concept:

Piles installation is followed by soil cutting. Ground anchors transmit retention forces to the distributing beam and enhance fixation of the retaining wall into the body of the slope. The curtain wall is installed in order to prevent ground spilling into the cavities between piles. The backfill is supplemented by erosion protection. Soil cutting allows to execute terrain redevelopment according to the project requirements.

Unique features of the standard design solution:

- Features properties of a piled wall;
- Long-lasting method of landslide protection;
- Essential for landslide protection of the transport objects constructed in challenging environments;

Standard design solutions for engineering protection

Section 1	Landslide protection
Subsection 2	Piled retaining wall on a slope

General view

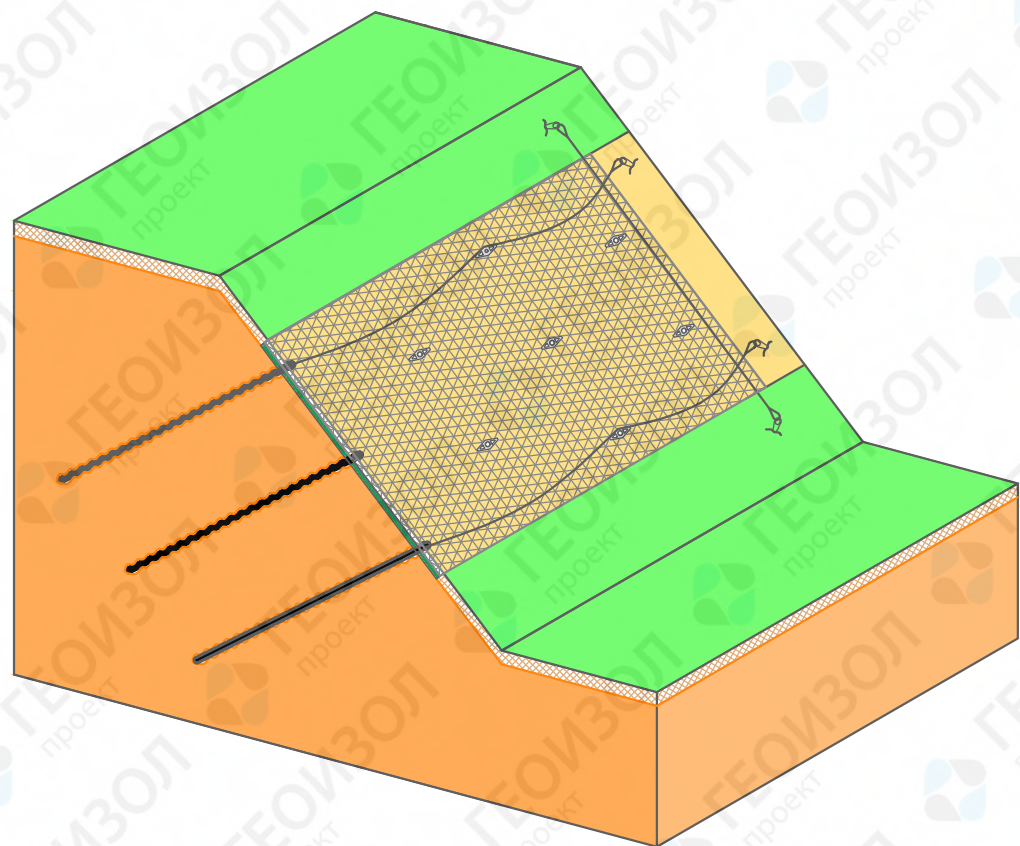

Sectional view

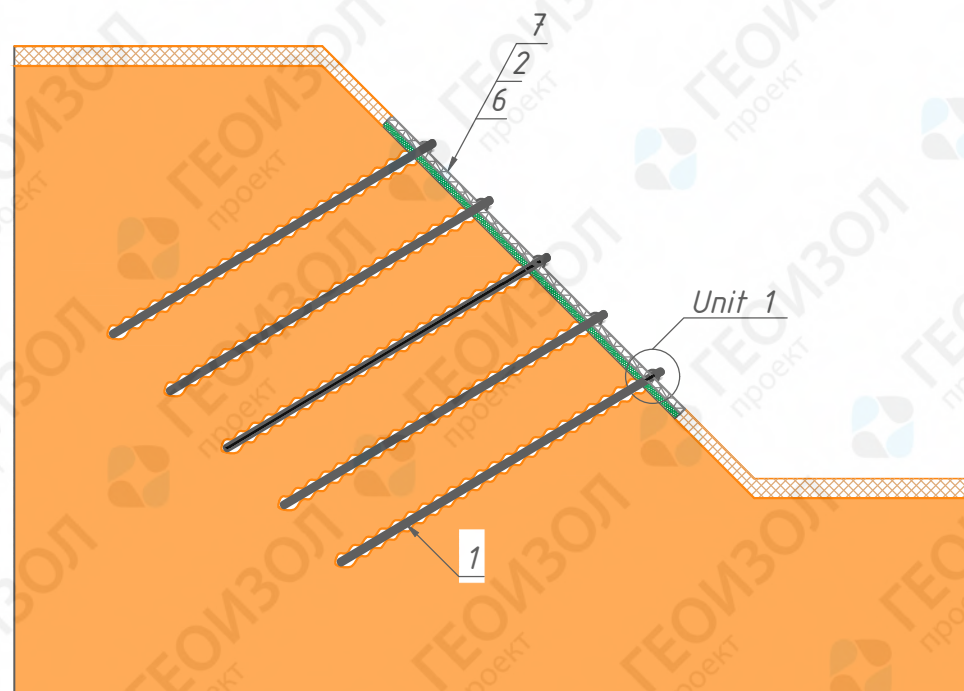

Unit 1

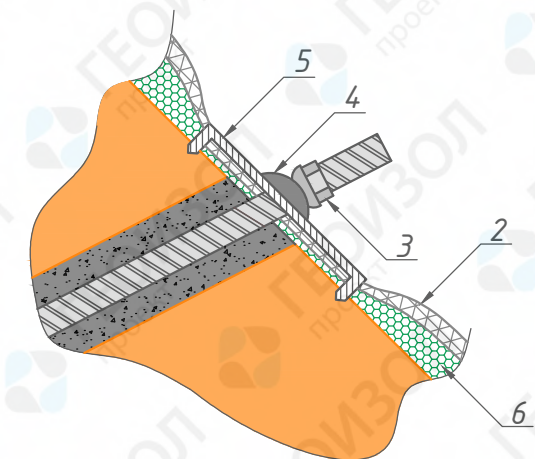

Claw plate



Examples of the existing objects



№	Nomination
1	Soil nail
2	Covering system
3	Spherical nut
4	Spherical seat
5	Claw plate
6	Erosion protection
7	Hydroseeding

Purpose:

- To strengthen landslide hazard slopes without topographical changes;
- Stone landslide protection.

Operation concept:

Nails go through the slickensided surface of the slope and get anchored into landslide-resistant ground. The claw plate of the covering system presses the terrain and prevents soil disbalance and stone landslide.

Unique features of the standard design solution:

- Allows to stabilize soil body without changes in terrain;
- Supplements the solution with the elements of erosion protection;
- Fixes longer extents of the slope;
- Maintains natural landscaping of the slope.

Standard design solutions for engineering protection

Section 1	Landslide protection
Subsection 3	Nail strengthening of a slope

General view

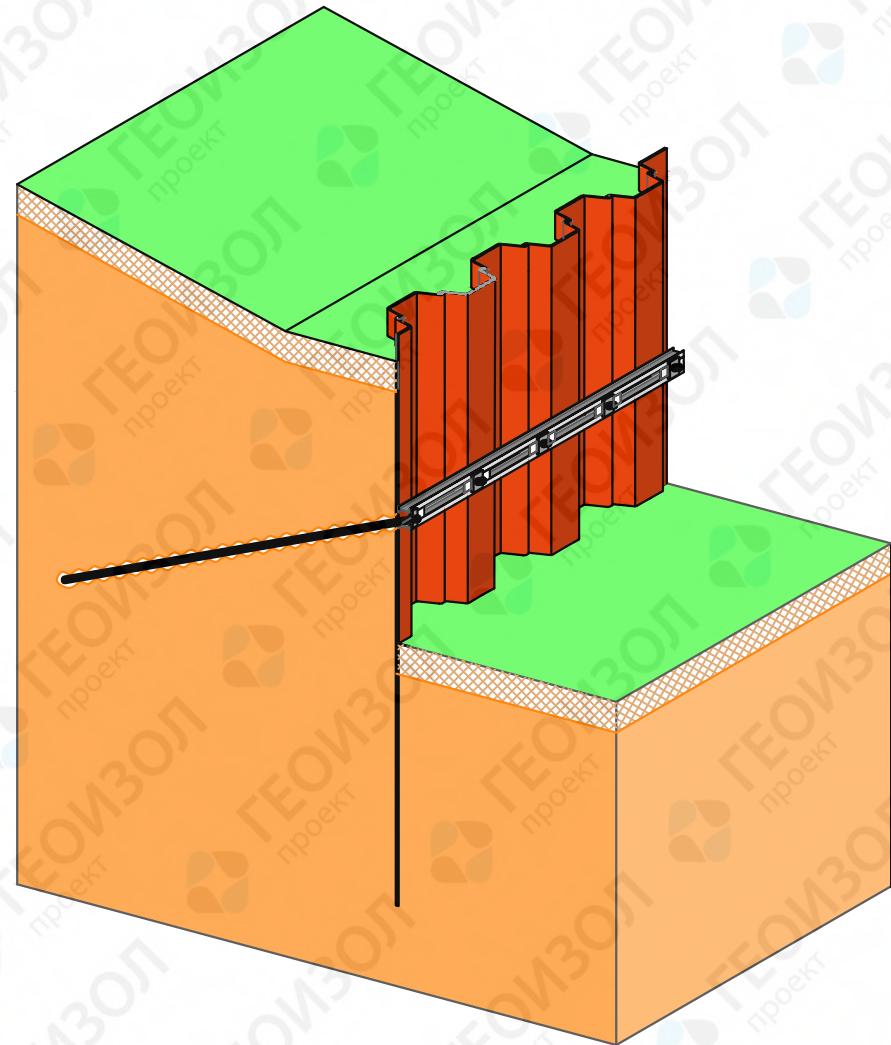

Sectional view

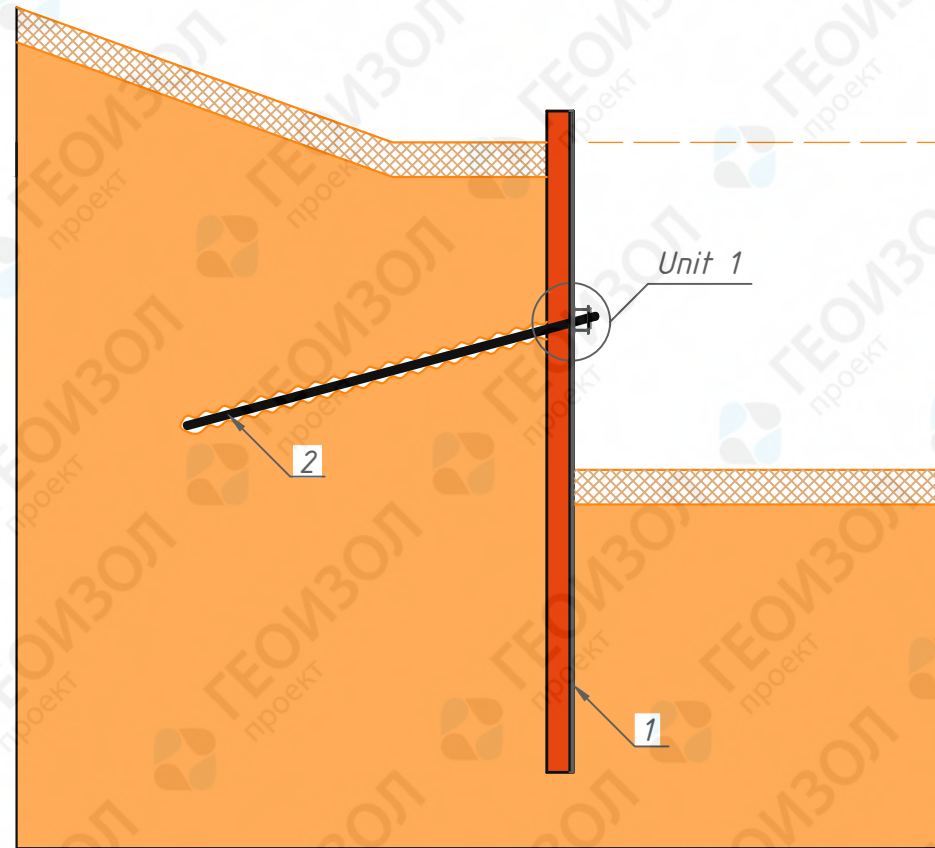

Unit 1

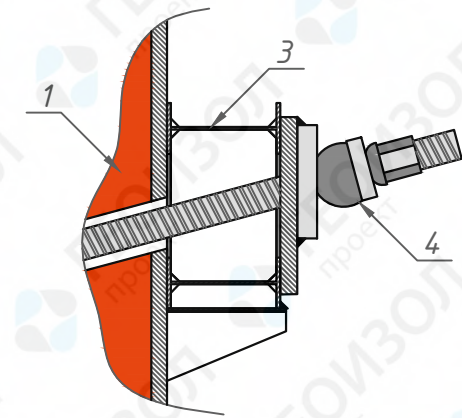

№	Nomination
1	Sheetpile wall
2	Ground anchor
3	Distributing beam
4	Set of anchor rod holder

Examples of the existing objects



Purpose:

- To strengthen landslide hazard slopes with topographical changes.

Operation concept:

Sheetpile wall installation is followed by soil cutting. Ground anchors transmit retention forces to the distributing beam and enhance fixation of the retaining wall into the body of the slope. The sheetpile wall allows to execute terrain redevelopment and to prepare the surface for the objects construction.

Unique features of the standard design solution:

- Comparatively simple working methods;
- Possible multiple usage of the elements;
- Essential for installing pits in challenging environments.

Standard design solutions for engineering protection		
Section 1	Landslide protection	
Subsection 4	Sheetpile retaining wall	

General view

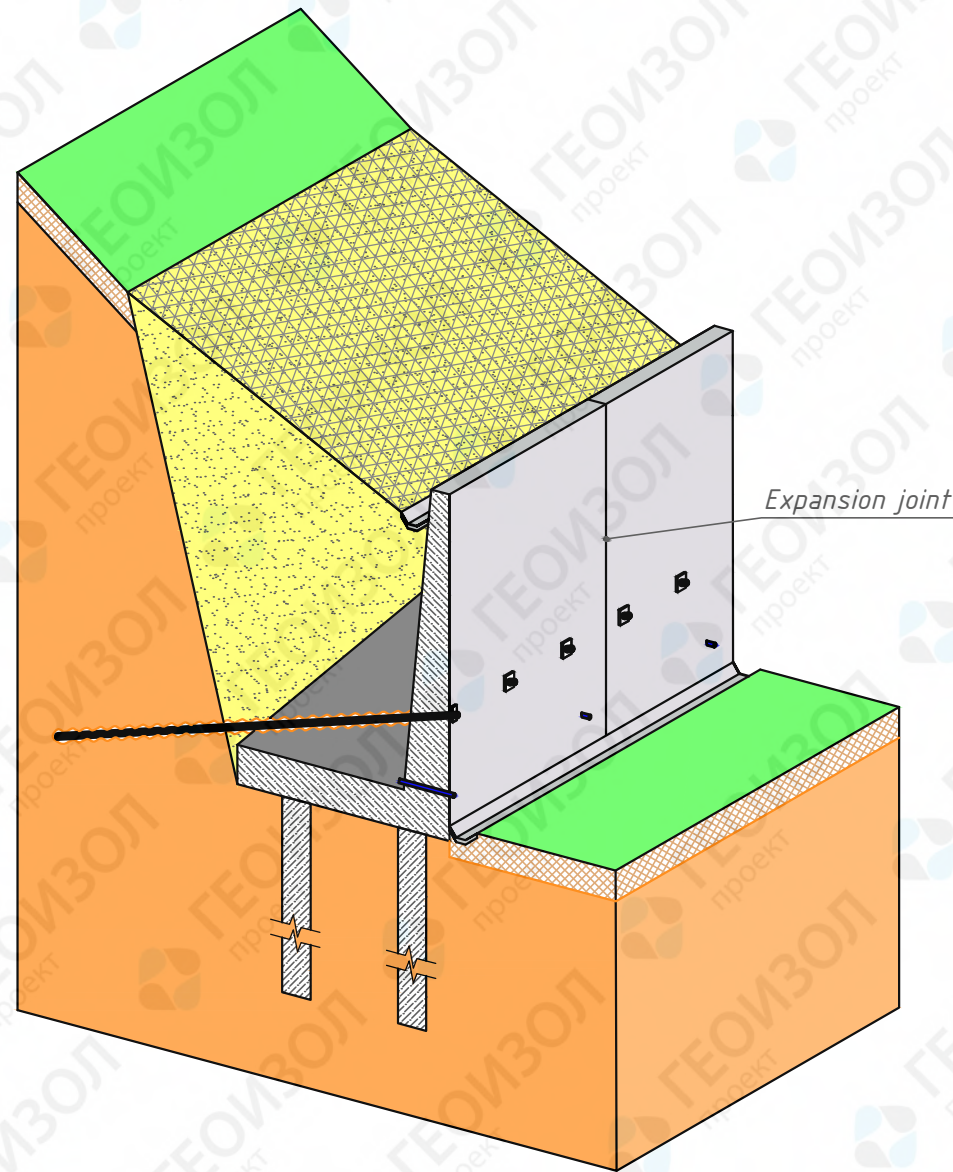

Sectional view

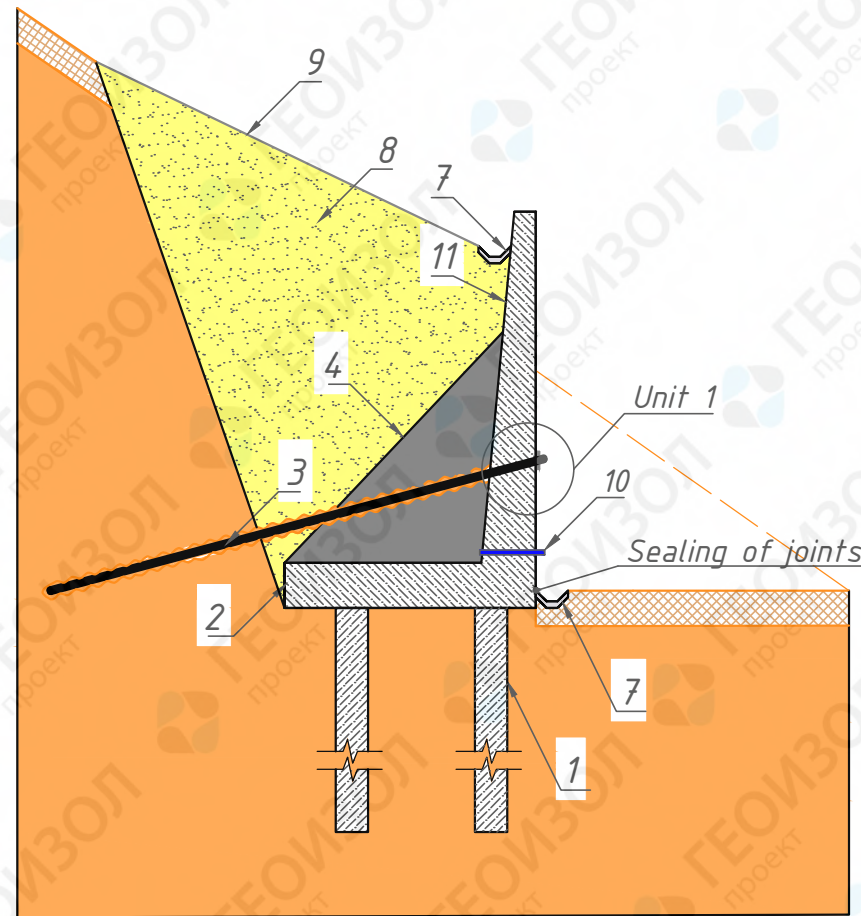

Unit 1

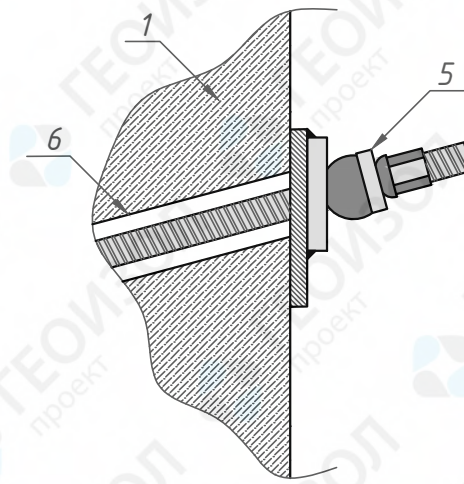

№	Nomination
1	Piles
2	L-shaped retaining wall
3	Ground anchor
4	Ribbed stiffener
5	Set of anchor rod holder
6	Embedded detail
7	Water gutter
8	Backfill
9	Erosion protection
10	Drainage pipe
11	Waterproofing

Examples of the existing objects



Purpose:

- To strengthen landslide hazard slopes with topographical changes;
- Erosion protection.

Operation concept:

Soil is cut and the L-shape wall is installed. Ground anchors transmit retention forces to the elements of the retaining wall. The L-shape of the wall enhances its stability as a result of surcharging. The ribs provide additional stiffening to the whole construction. The backfill is supplemented by erosion protection. Soil cutting allows to execute terrain redevelopment according to the project requirements.

Unique features of the standard design solution:

- Features properties of a piled wall;
- Allows to strengthen larger amounts of soil;
- Increased stability and strength.

Standard design solutions for engineering protection

Section 1	Landslide protection
Subsection 5	Retaining wall on artificial foundation bed

General view

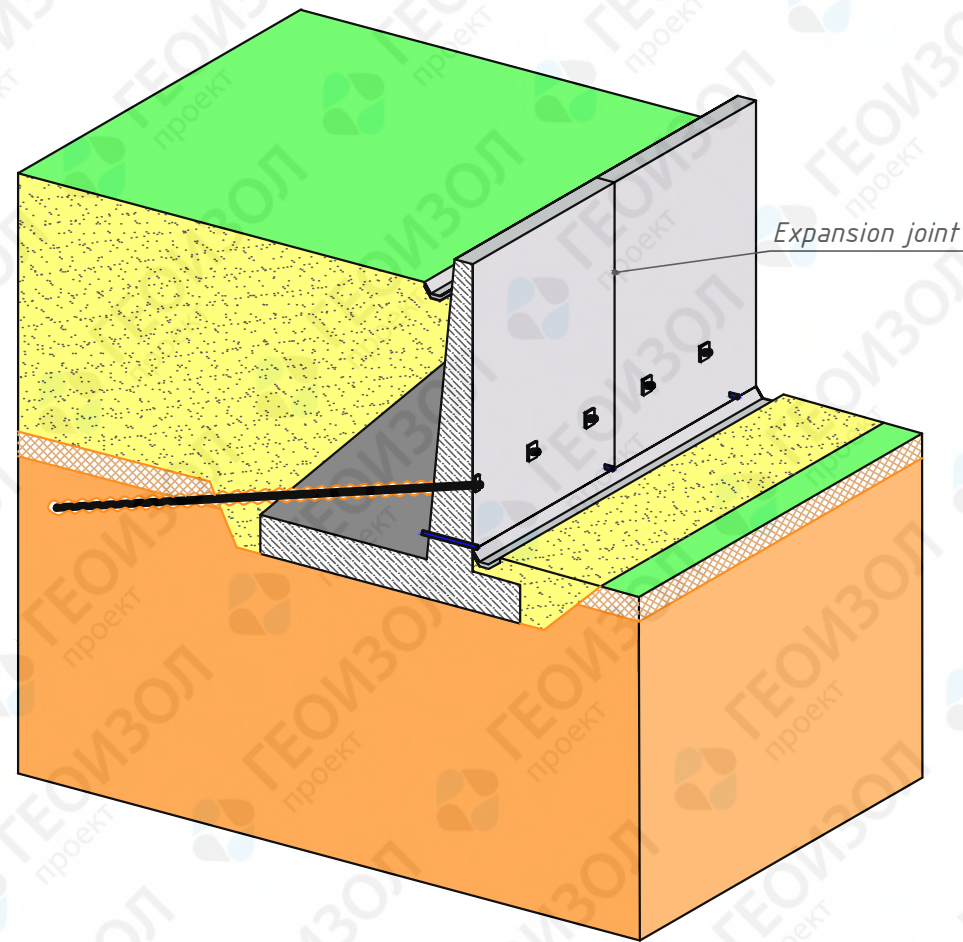

Sectional view

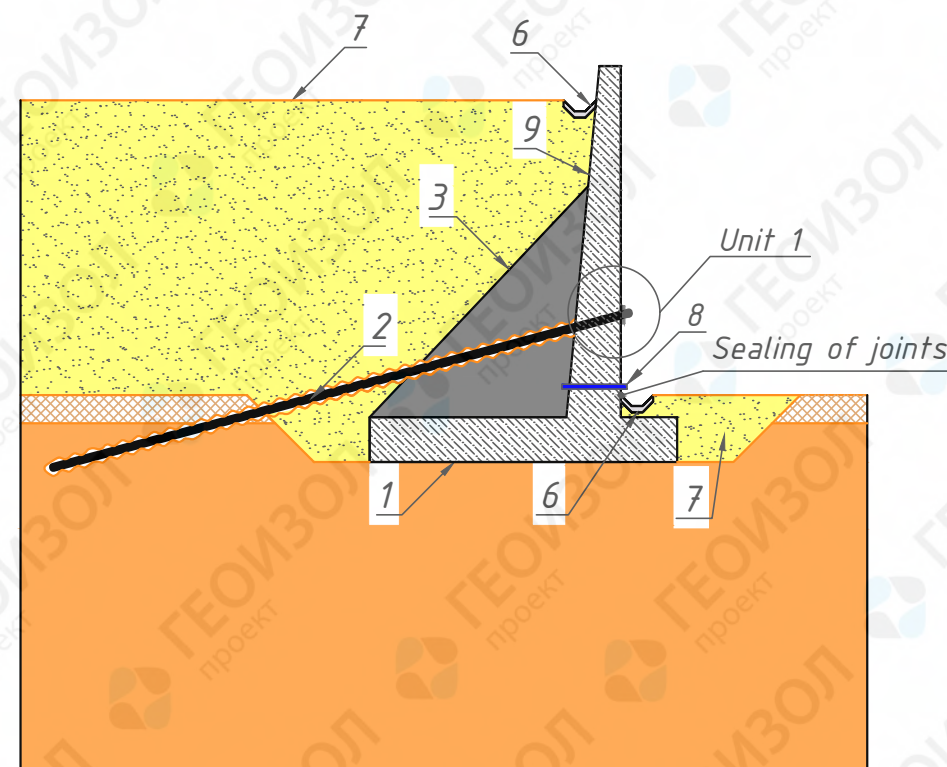

Unit 1

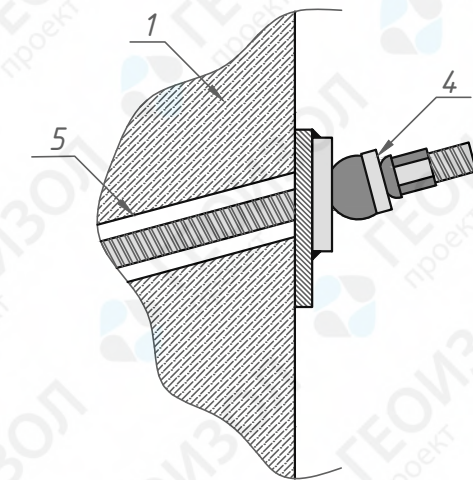

№	Nomination
1	L-shaped retaining wall
2	Ground anchor
3	Ribbed stiffener
4	Anchor rod fastening set
5	Embedded detail
6	Water gutter
7	Soil fill
8	Drainage pipe
9	Waterproofing

Examples of the existing objects



Purpose:

- To strengthen landslide hazard slopes with topographical changes;
- To create artificial rising ground.

Operation concept:

A pit for installation of a L-shaped retaining wall is dug. Ground anchors transmit retention forces to the elements of the retaining wall. The L shape of the wall enhances its stability as a result of surcharging. Its massive substructure allows to exclude artificial foundations. Soil fill forms the terrain according to the project requirements.

Unique features of the standard design solution:

- Features properties of a piled wall;
- Allows land rising;
- Excludes piles installation.

Standard design solutions for engineering protection

Section 1	Landslide protection
Subsection 6	Retaining wall on natural foundation bed

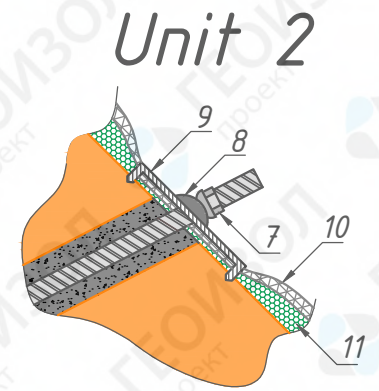
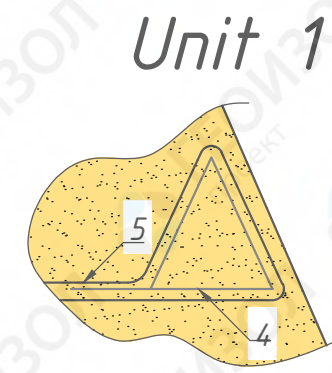
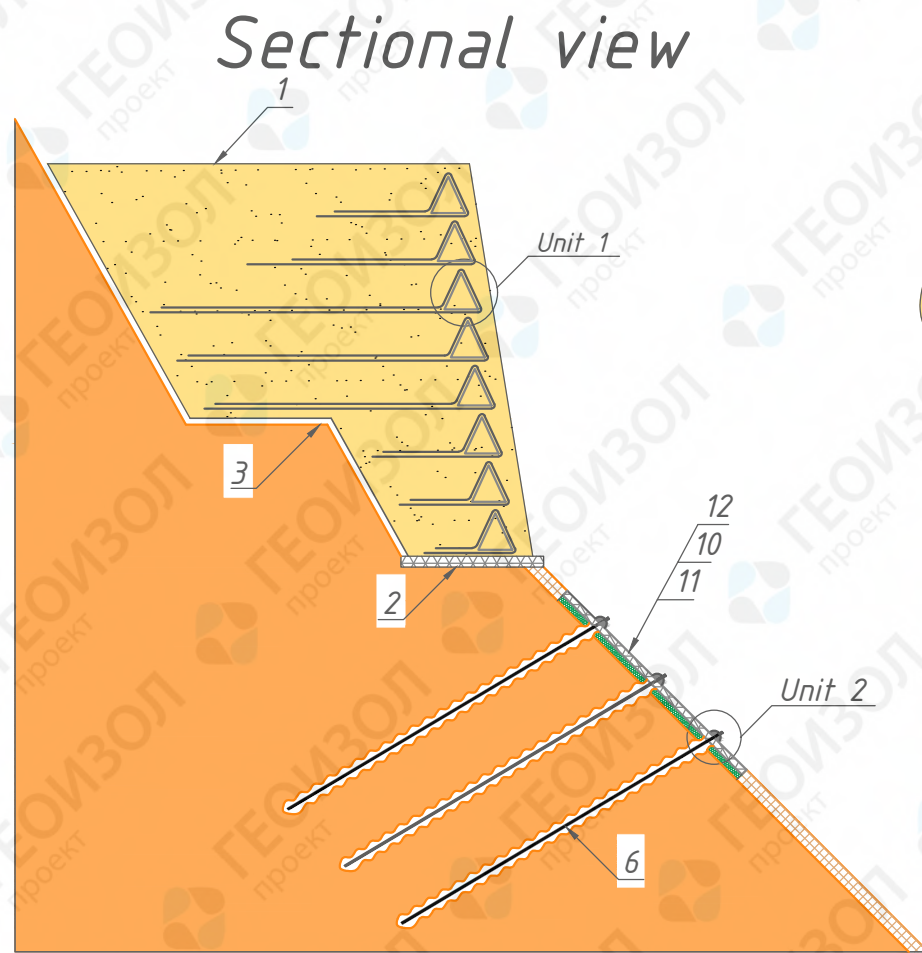
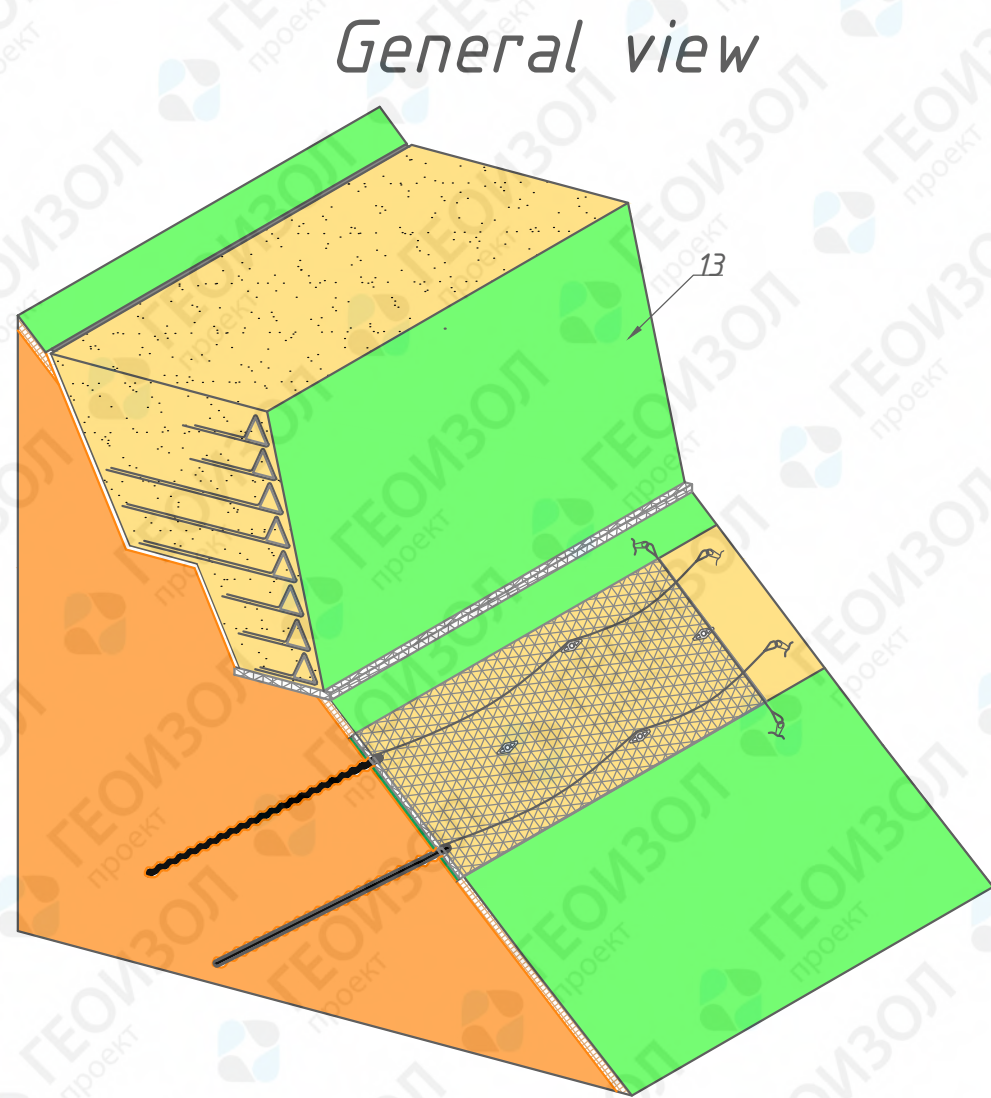

№	Nomination
1	Reinforced retaining wall
2	Mattress gabion
3	Parallel drainage
4	Reinforcement cage
5	Geogrid
6	Soil nail
7	Spherical nut
8	Spherical seat
9	Claw plate
10	Covering system
11	Erosion protection
12	Hydroseeding
13	Facing section of the Terramesh system

Examples of the existing objects



Purpose:

- To strengthen landslide hazard slopes with topographical changes;
- Erosion protection;
- Infrastructure construction.

Operation concept:

Soil is cut according to the project and reinforced by the cages wrapped in geogrid. Free lengths of the geogrids are filled by stiff drainage soil. Parallel drainage protects the reinforced retaining wall from ground water. Soil nailing of the slope protects the area below the retaining wall from landslides.

Unique features of the standard design solution:

- Essential for landslide protection of the transport objects constructed in challenging environments;
- Allows construction in tight conditions.

Standard design solutions for engineering protection

Section 1	Landslide protection
Subsection 7	Reinforced retaining wall (type 1)

General view

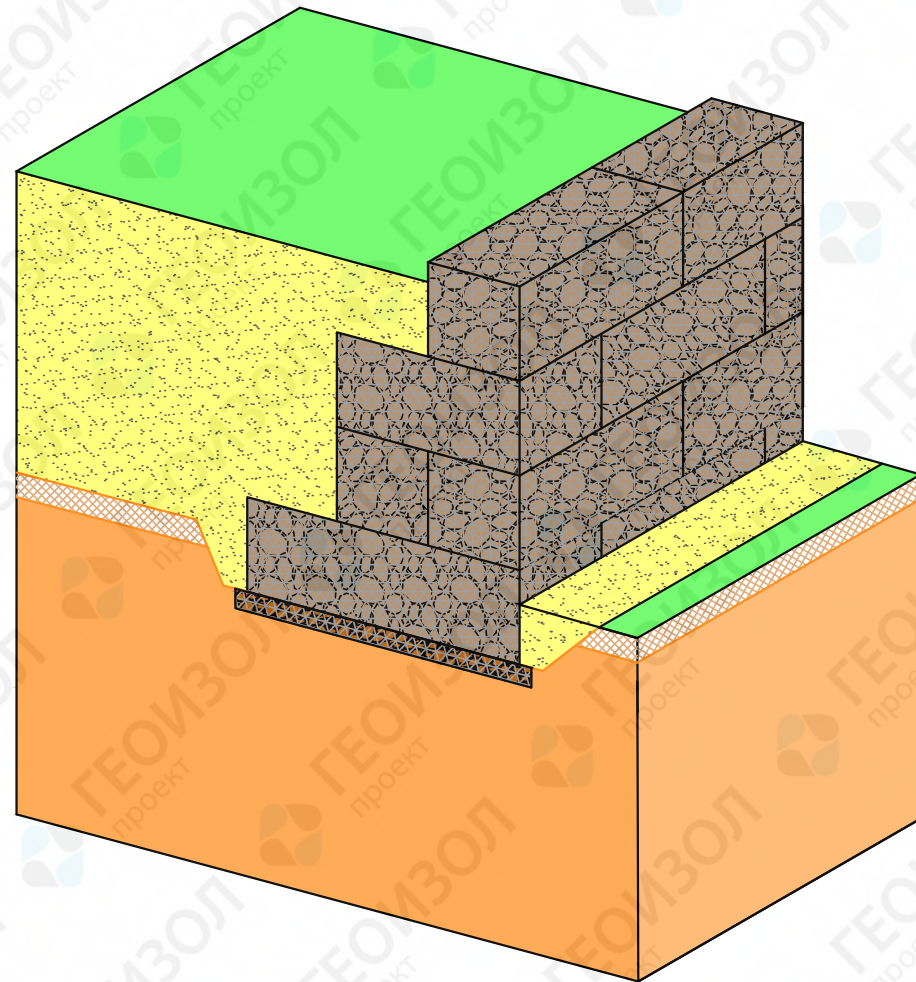

Sectional view

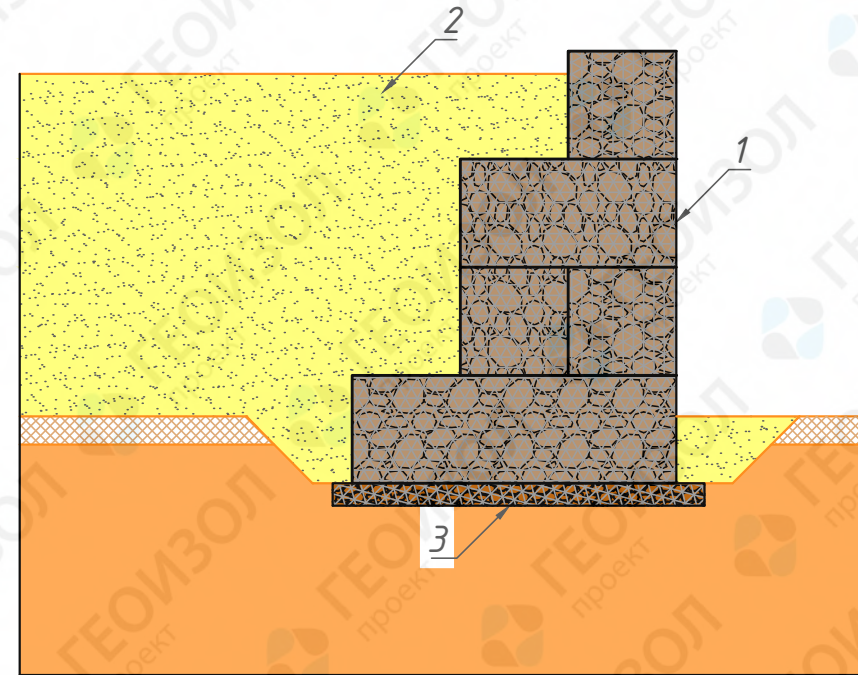

№	Nomination
1	Gabion retaining wall
2	Soil fill
3	Mattress basement

Examples of the existing objects

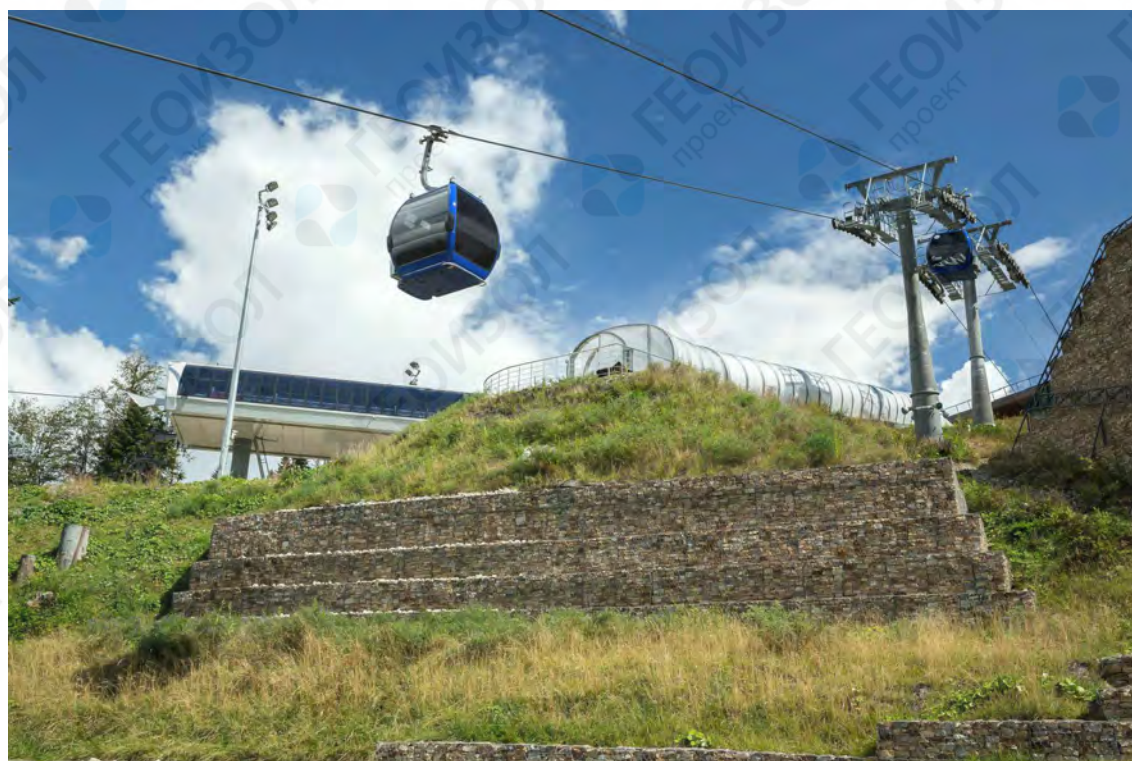

Purpose:

- To strengthen landslide hazard slopes with minor topographical changes;
- To create artificial rising ground.

Operation concept:

A pit for installation of the mattress basement is dug. Gabion retaining wall is constructed from box-shaped gabions. In order to stiffen the structure the cages of the gabions may be connected to each other. After the required sizes of the structure are achieved it is filled by soil.

Unique features of the standard design solution:

- Simple technology of the works;
- Wide spectrum of application;
- Allows land rising;
- Variety of construction forms and decoration styles.

Standard design solutions for engineering protection		
Section 1	Landslide protection	
Subsection 8	Gabion retaining wall	

General view

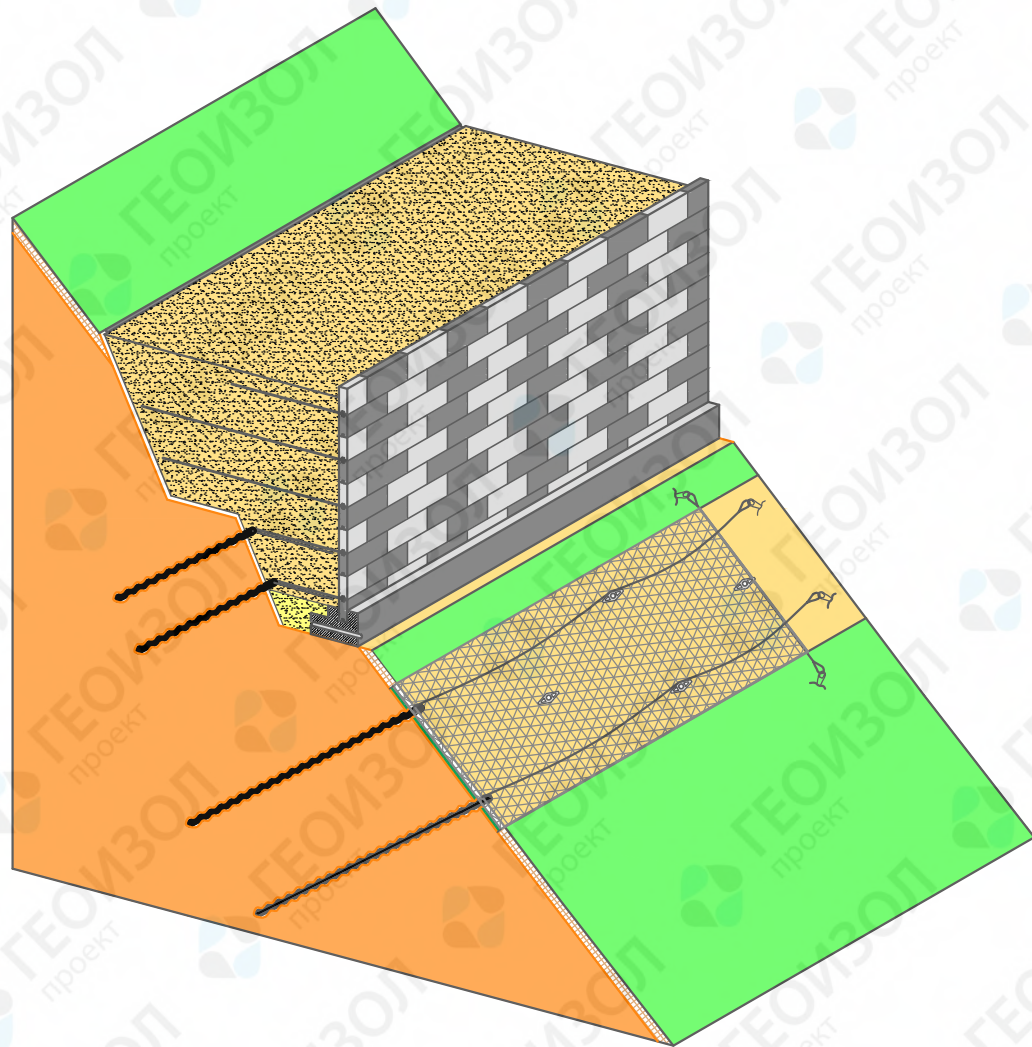

Sectional view

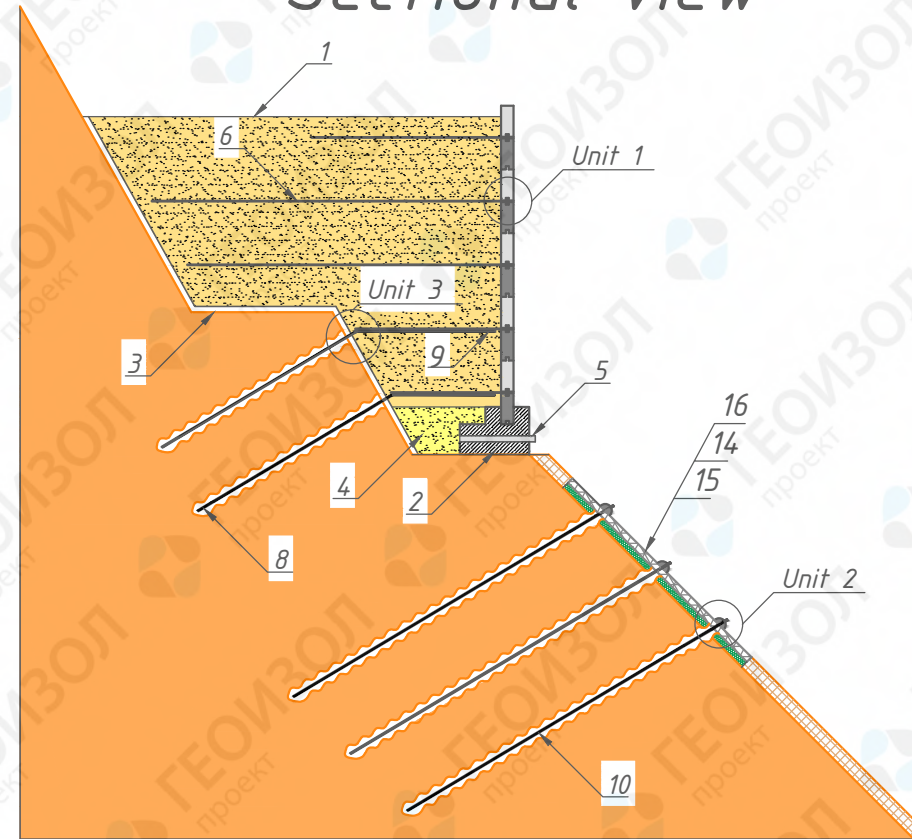

Unit 1

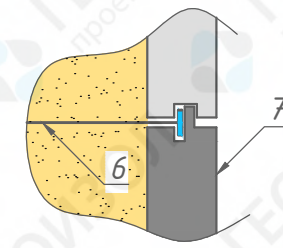

Unit 2

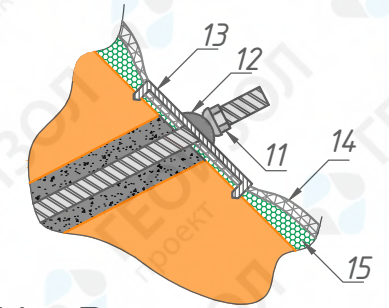

Unit 3

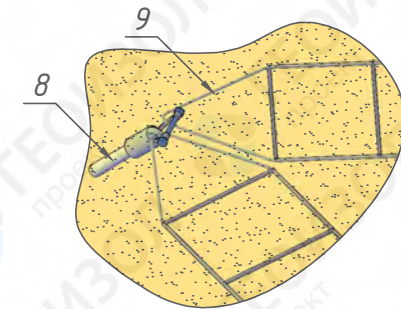

Examples of the existing objects



Purpose:

- To strengthen landslide hazard slopes with topographical changes;
- Erosion protection;
- Infrastructure construction.

Operation concept:

Soil is cut according to the project. Soil is reinforced by geogrids embedded into face panels of the reinforced retaining wall. Foundation with slots serves as a basement for the face panels. The wall is enhanced by using ground anchors that transmit retention forces to the reinforced retaining wall through special elements.

Unique features of the standard design solution:

- Suitable for high slopes;
- Small amount of backfill;
- Allows construction in tight conditions
- Essential for landslide protection of the transport objects constructed in challenging environments.

№	Nomination
1	Reinforced ground retaining wall
2	Concrete foundation
3	Parallel drainage
4	Draining soil
5	Outlet of the drainage system
6	Geogrid
7	Facing section of the Reinforced retaining wall
8	Geogrid fixing anchor
9	Element transmitting forces from the geogrid to the Ground anchor
10	Soil nail
11	Spherical nut
12	Spherical seat
13	Claw plate
14	Covering system
15	Erosion protection
16	Hydroseeding

Standard design solutions for engineering protection

Section 1	Landslide protection	
Subsection 9	Reinforced retaining wall (type 2)	

General view

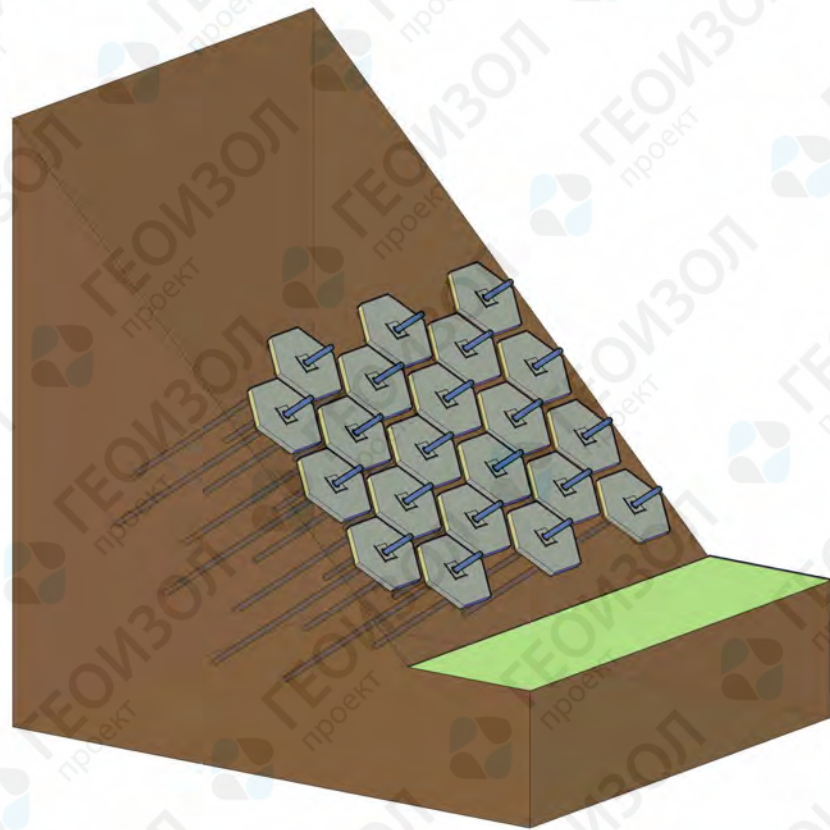

Sectional view

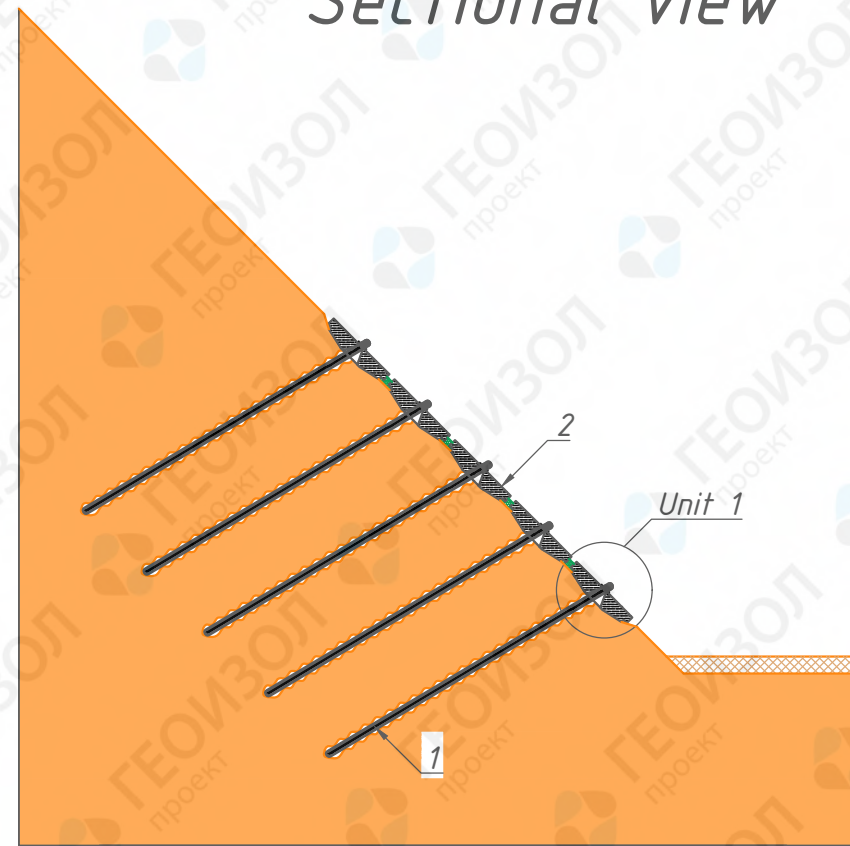

Unit 1

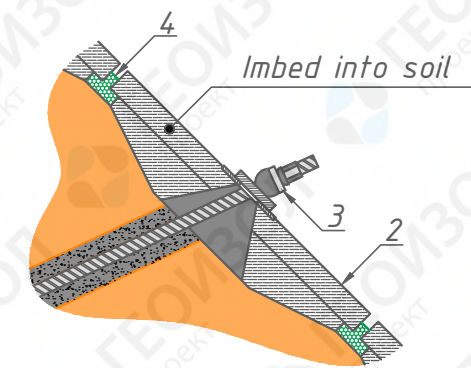
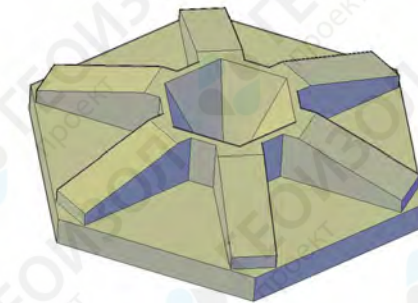

Plate view



Examples of the existing objects



№	Nomination
1	Ground anchor
2	Anchor plate
3	Anchor rod fastening set
4	Erosion protection

Purpose:

- To protect soil masses from different types of erosion
- Erosion protection.

Operation concept:

Anchors go through the failure surface of the slope to reach the stable soil. Armored concrete plates with high strength properties retain landslide hazardous masses of the slope. Geosynthetic between the plates prevent from erosion. The plates are pressed into the relief of the slope to enhance adhesion properties of the soil particles.

Unique features of the standard design solution:

- Features properties of nail structures;
- Suitable for works on loose ground;
- The anchor reinforces soil, the plate retains the slope.

Standard design solutions for engineering protection		
Section 1	Landslide protection	
Subsection 10	Anchorage with pressure plates	

General view

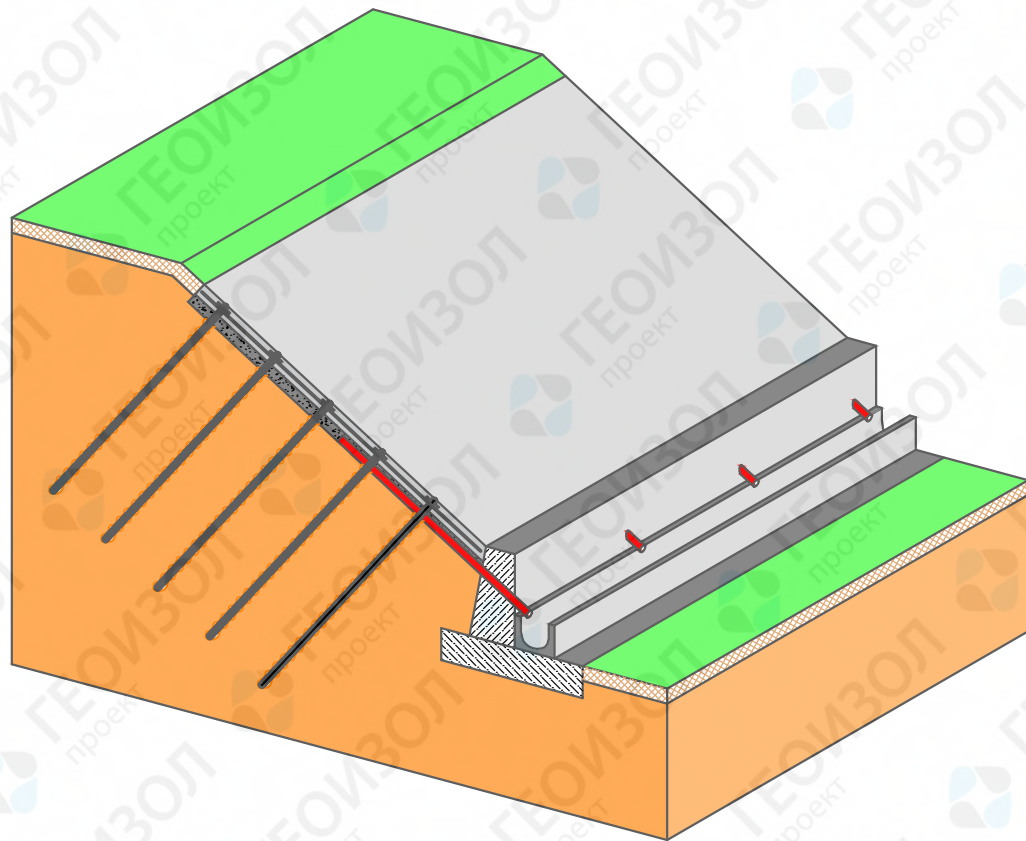

Sectional view

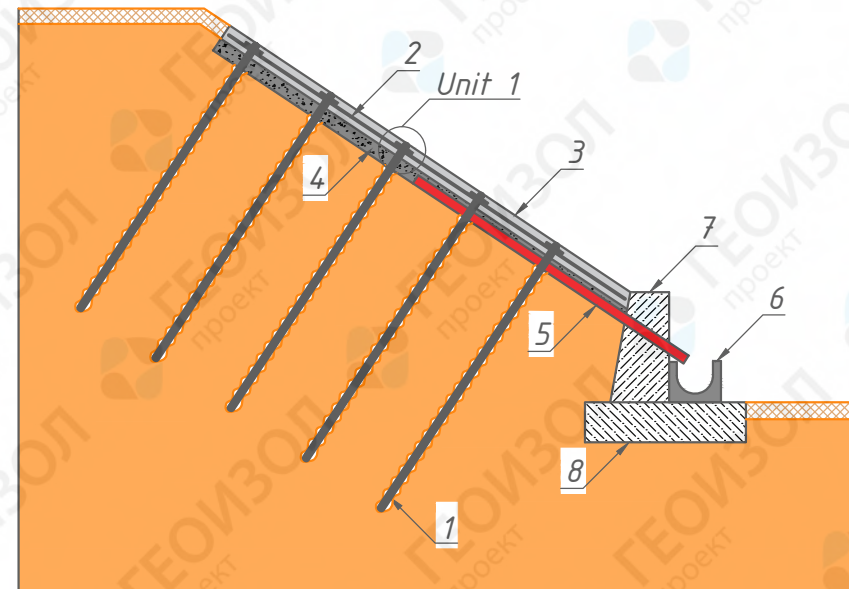

Unit 1

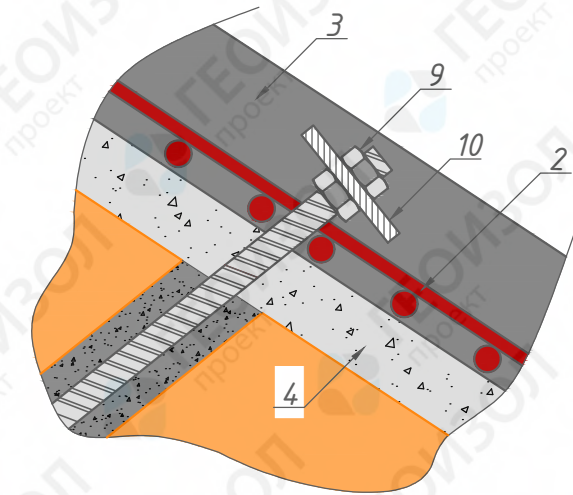

№	Nomination
1	Ground anchor
2	Reinforcement cage
3	Shotcreting
4	Crushed stone drainage bed
5	Drainage pipe
6	Drainage gutter
7	Retaining wal
8	Basement
9	Anchor nut
10	Anchor plate

Examples of the existing objects



Purpose:

- To strengthen landslide hazard slopes with minor topographical changes;
- Erosion protection;

Operation concept:

Anchors go through the failure surface of the slope to reach the stable soil. The construction of the reinforcement cage provides joint work of the ground anchors. Shotcreting is streamlike spraying of concrete to the slope surface. The construction combines properties of reinforcing steel and concrete thus forming durable coating to retain the the slope. The anchors reinforce the soil and retain the shotcreted slope.

Unique features of the standard design solution:

- Combines properties of anchor structures and pressure plates;
- Aesthetically and architecturally balanced type of the ready object;
- Solid and homogeneous construction.

Standard design solutions for engineering protection

Section 1	Landslide protection
Subsection 11	Slope shotcreting

Section 2
Erosion protection

General view

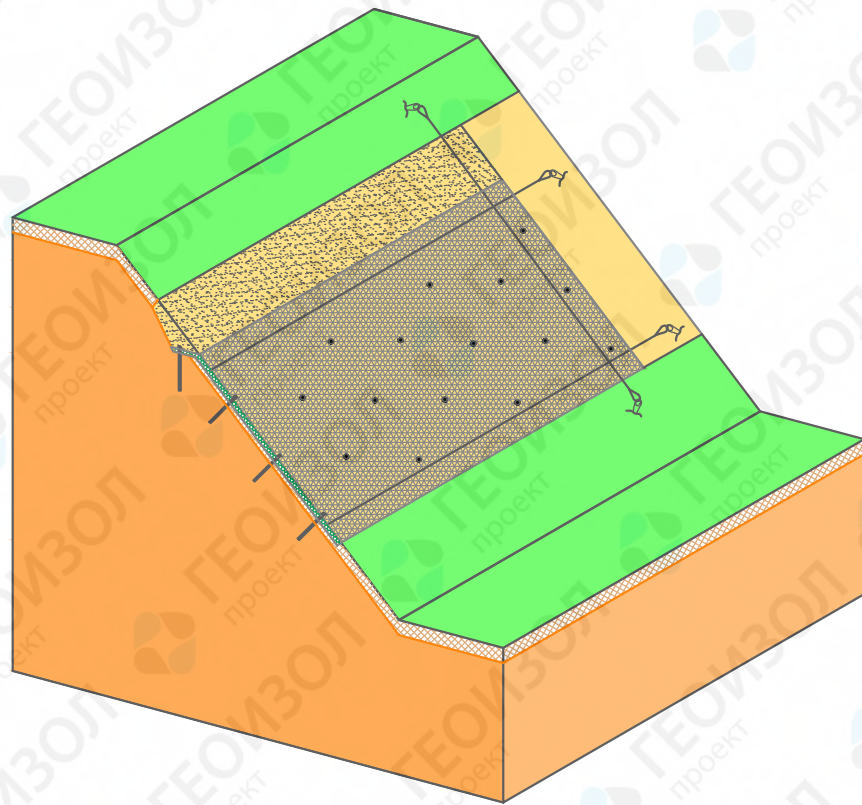

Sectional view

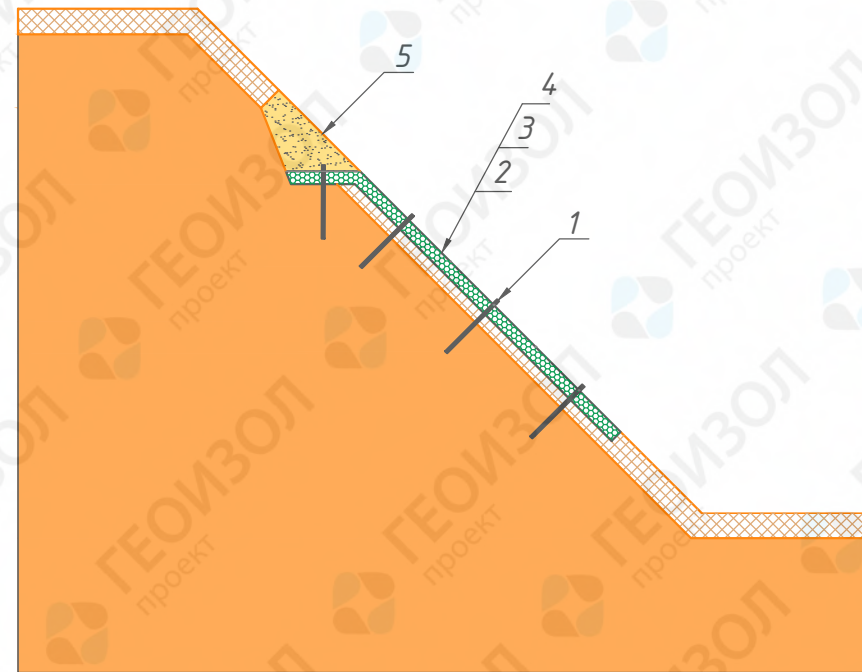

№	Nomination
1	Ground anchoring rod
2	Erosion protection
3	Covering system
4	Hydroseeding
5	Soil fill

Examples of the existing objects



Purpose:

- To protect soil masses from different types of erosion.

Operation concept:

Geosynthetic and covering system are laid to the surface of the strengthened relief. Ground anchoring rods serve to fix the construction. Upper edge of the mat is embedded into the soil and backfilled to secure anchoring. Geosynthetic reinforces root system and prevents removal of the soil particles during hydroseeding.

Unique features of the standard design solution:

- Long-lasting protection;
- Possibility to find an individual solution;
- Simple technology of the works;
- Allows to stabilize longer slopes;
- Maintains natural vegetation of the slope.

Standard design solutions for engineering protection

Section 2	Erosion protection	
Subsection 1	Erosion protection	

Section 3
Water disposal

General view

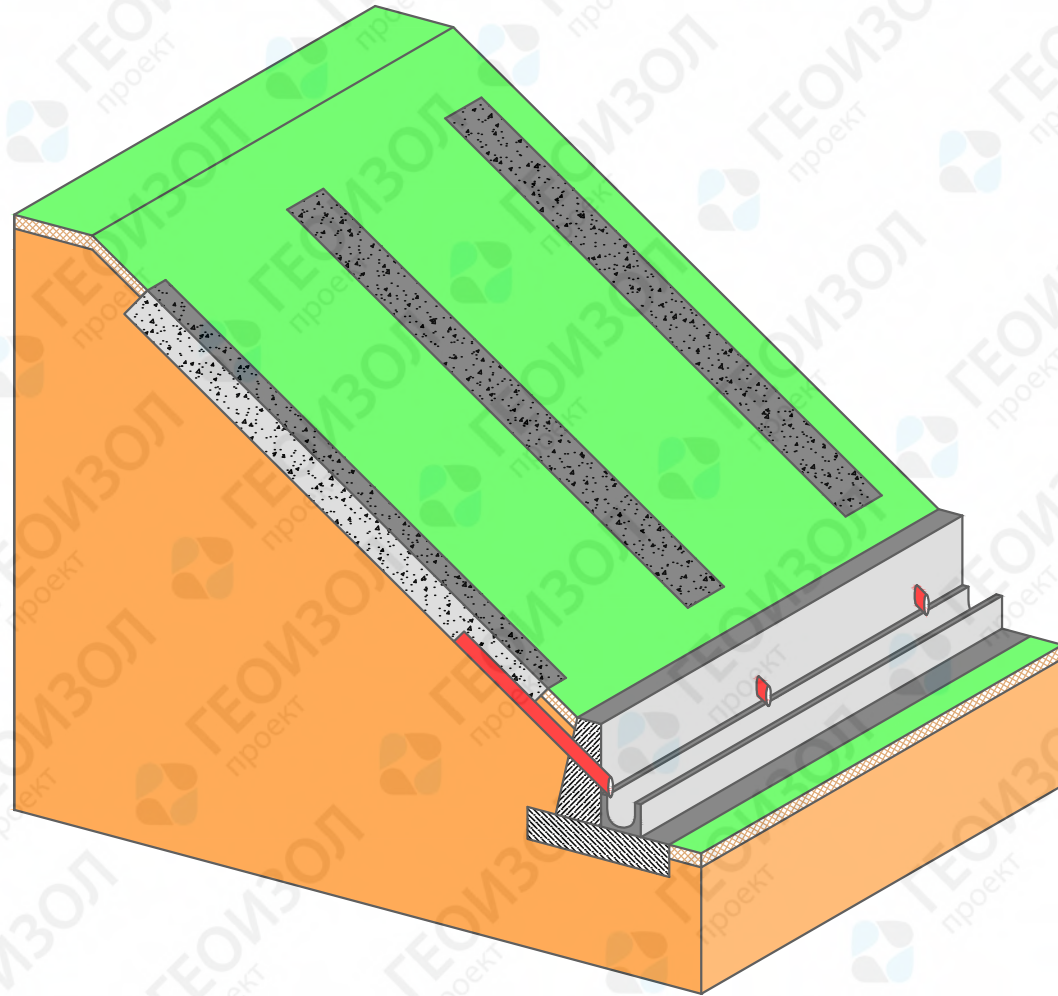

Sectional view

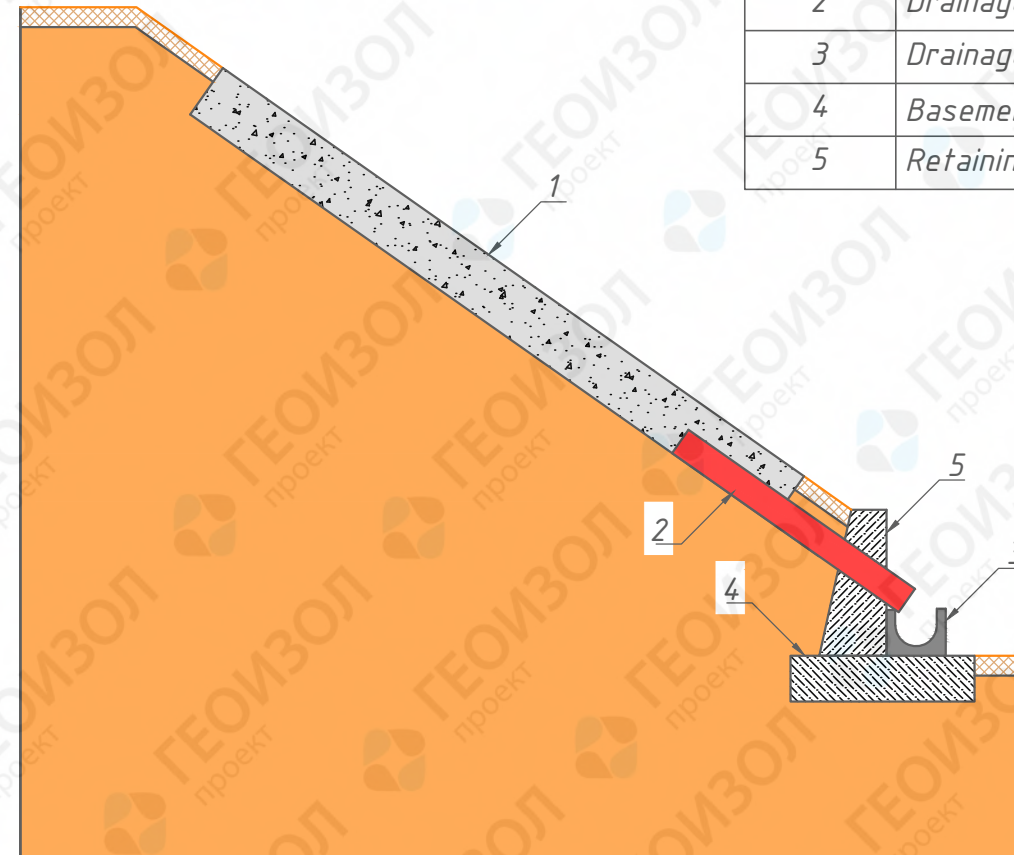

№	Nomination
1	Rock drain
2	Drainage pipe
3	Drainage gutter
4	Basement
5	Retaining wall

Examples of the existing objects



Purpose:

- To prevent water supersaturation.

Operation concept:

Drainage is required to remove excess of moisture from the soil as saturated particles are likely to move. Drainage trenches are dug and filled by draining soil. Drainage pipe settled into the trench collects water into the drainage gutter. Drainage is required to maintain various types of constructions.

Unique features of the standard design solution:

- Prevents landslides and erosion;
- Allows to use the collected water;
- Maintains natural vegetation of the slope.

Standard design solutions for engineering protection

Section 3	Water disposal	
Subsection 1	Drainage	

General view

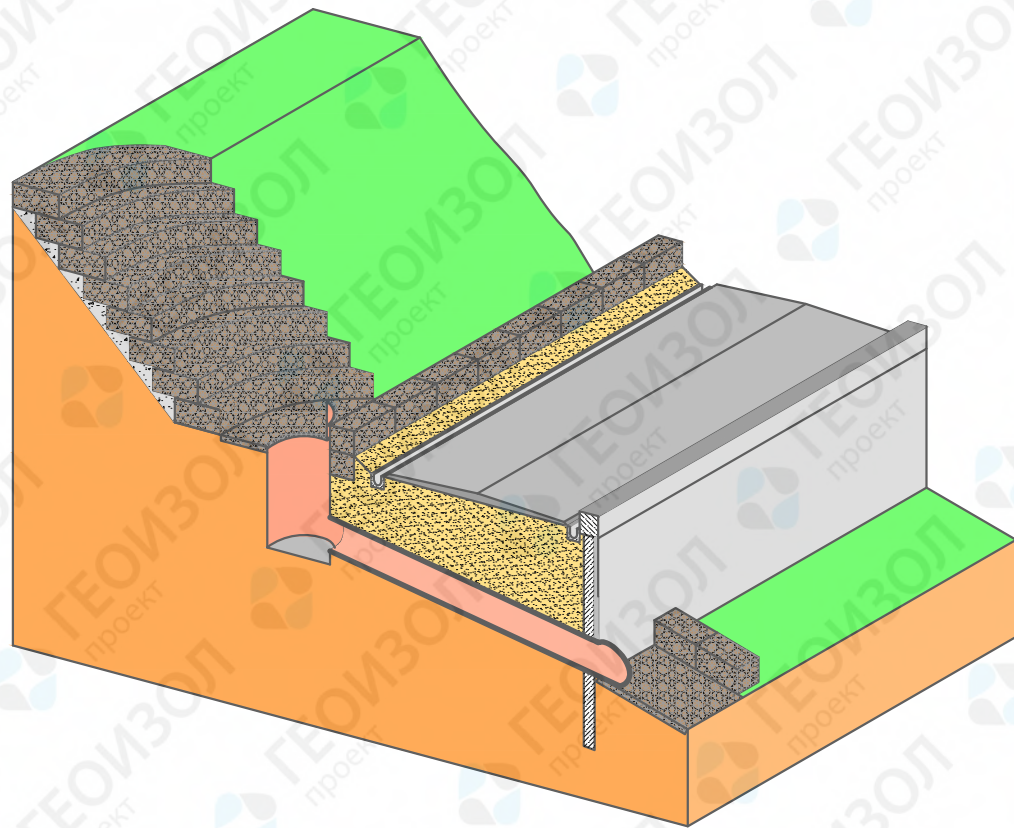

Sectional view

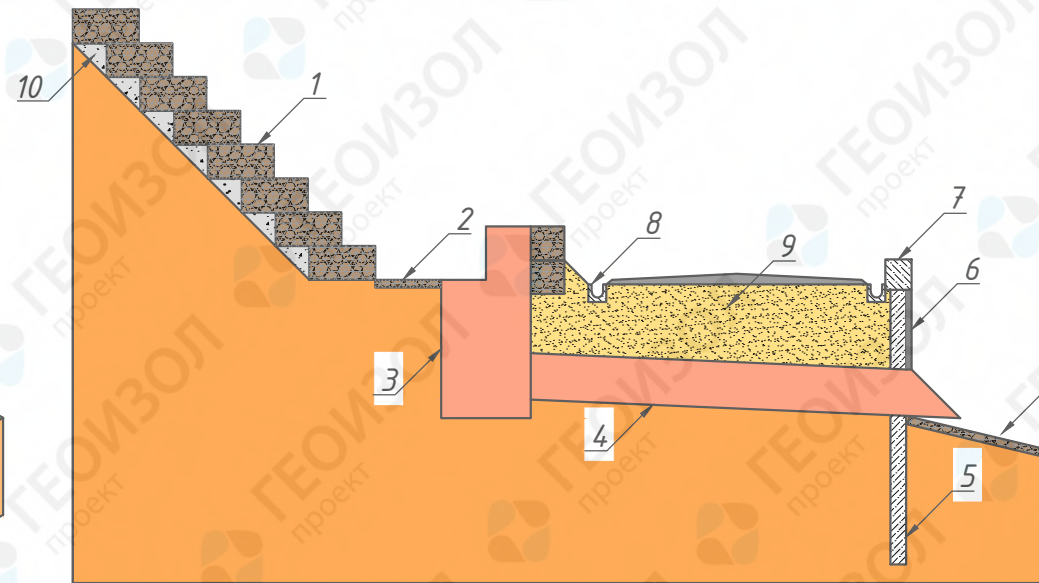

№	Nomination
1	Box-shaped gabions
2	Shock absorber
3	Culvert inlet well
4	Pipe culvert
5	Piled wall
6	Curtain wall
7	Spandrel beam
8	Water gutter
9	Soil fill
10	Crushed stone fill

Examples of the existing objects



Purpose:

- To provide a water pass through infrastructural facilities.

Operation concept:

The culvert is installed to run water through the body of the fill. Basic measurements and the type of the construction follow hydrologic calculations. In order to reduce the energy of the stream a set of conjugation structures is installed before the pipe. The form and material of the pipe's outlet fortification is chosen according to the degree of the washaway. The piled wall stiffens the construction and does not let the pipe decline from the position stated in the project.

Unique features of the standard design solution:

- Allows to run piping without underflooding of the backfill;
- Essential for construction in mountainous areas.

Standard design solutions for engineering protection

Section 3	Water disposal	
Subsection 2	Culvert	

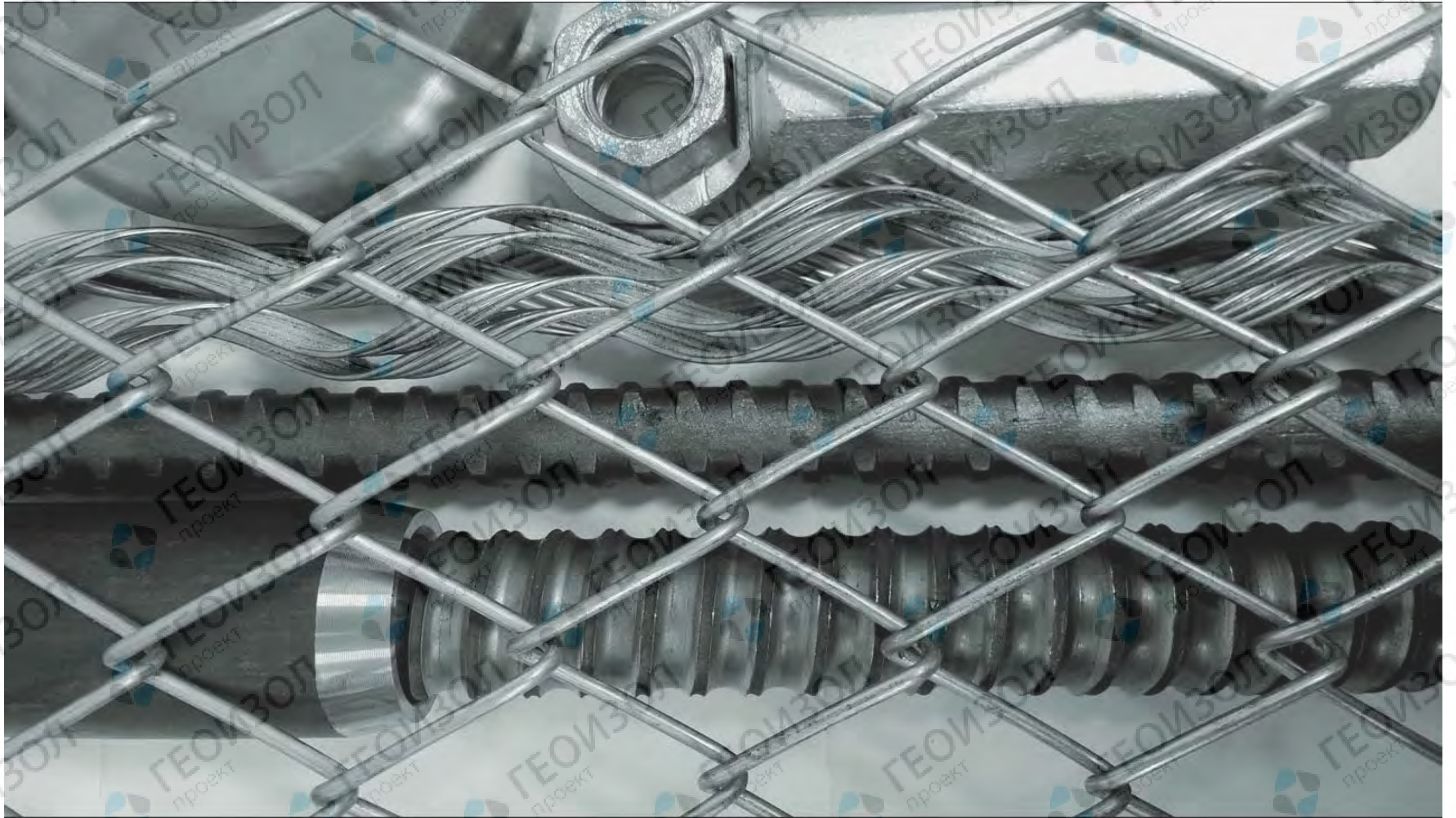

Section 4
Rockfall protection, mudslide
protection, etc.

General view

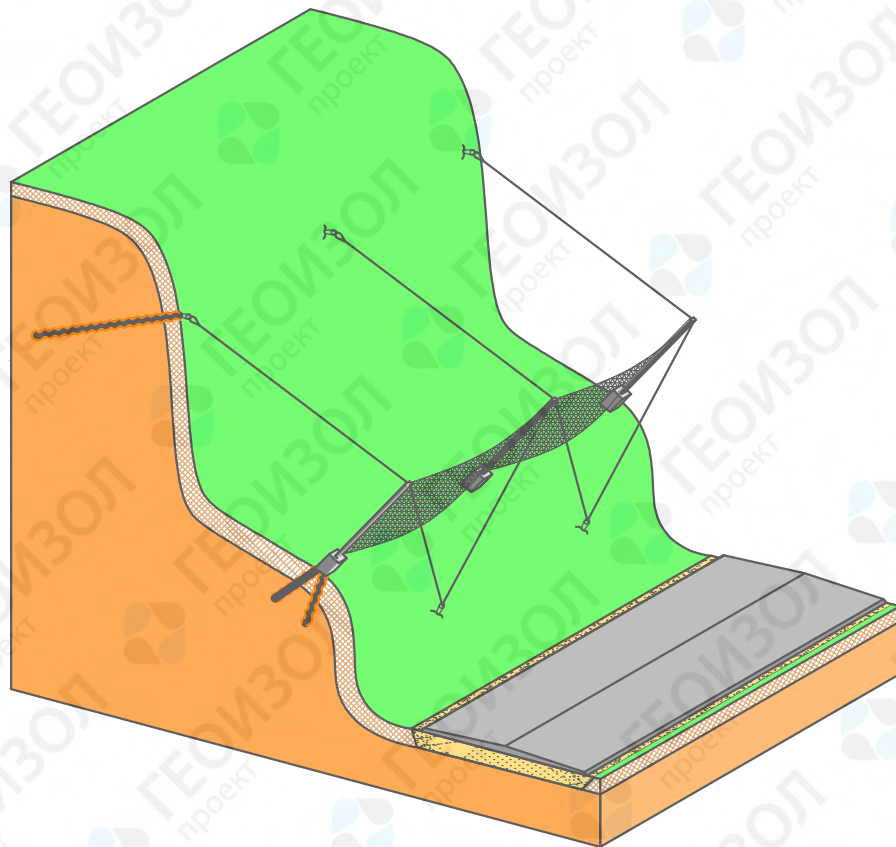

Sectional view

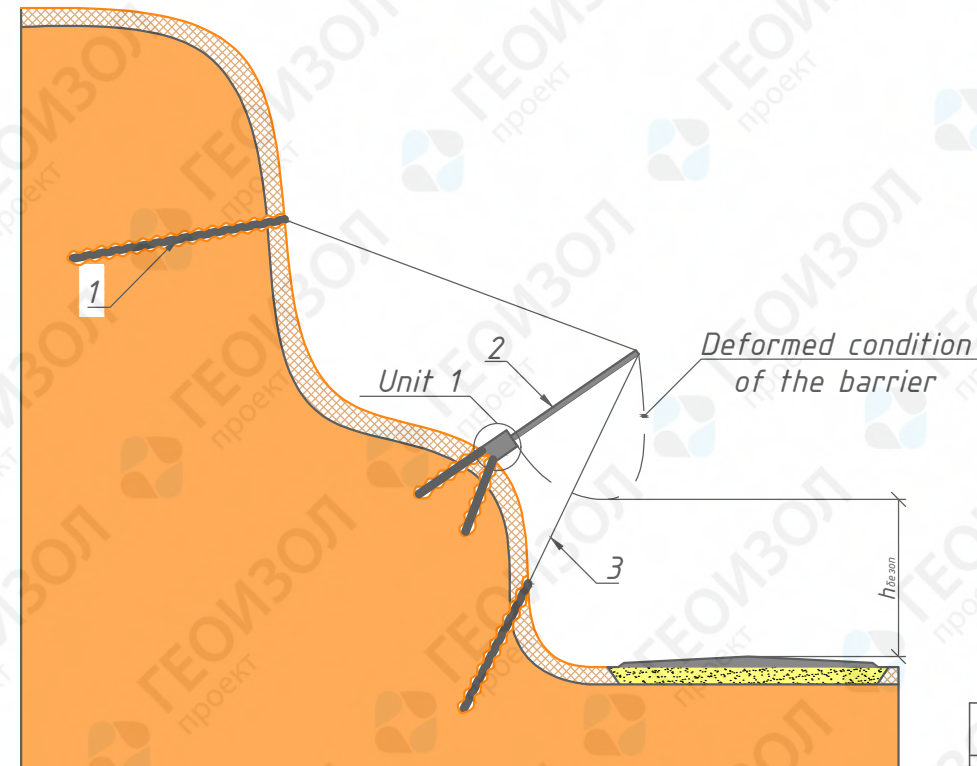

Unit 1

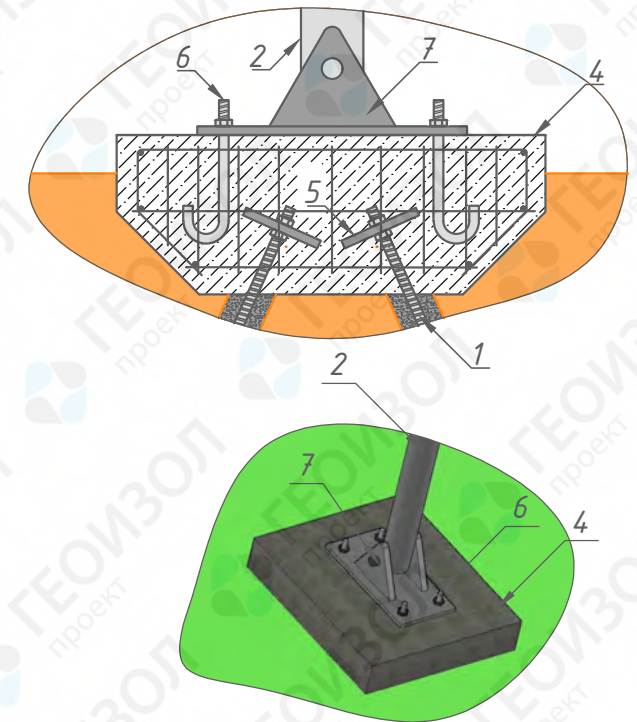

Examples of the existing objects



№	Nomination
1	Ground anchor
2	Post and ring net
3	Retaining rope
4	Ground anchor grillage
5	Anchor plate
6	Anchor bolt
7	Hinged support part

Purpose:

- To prevent rockfall onto infrastructural facilities.

Operation concept:

Barrier is installed across a slope. Posts are mounted on a hinged support part to provide rotation in the area of rockfall impact. Retaining ropes hold the posts of the barrier. Ground anchors embed the elements of the barrier into the relief.

Unique features of the standard design solution:

- High bearing capacity;
- Absorbs the energy of the falling rock debris through deformation of the barrier elements and ring net;
- Allows to stabilize longer slopes.

Standard design solutions for engineering protection

Section 4 Rockfall protection, mudslide protection, etc.

Subsection 1 Rockfall protection barrier

General view



Sectional view

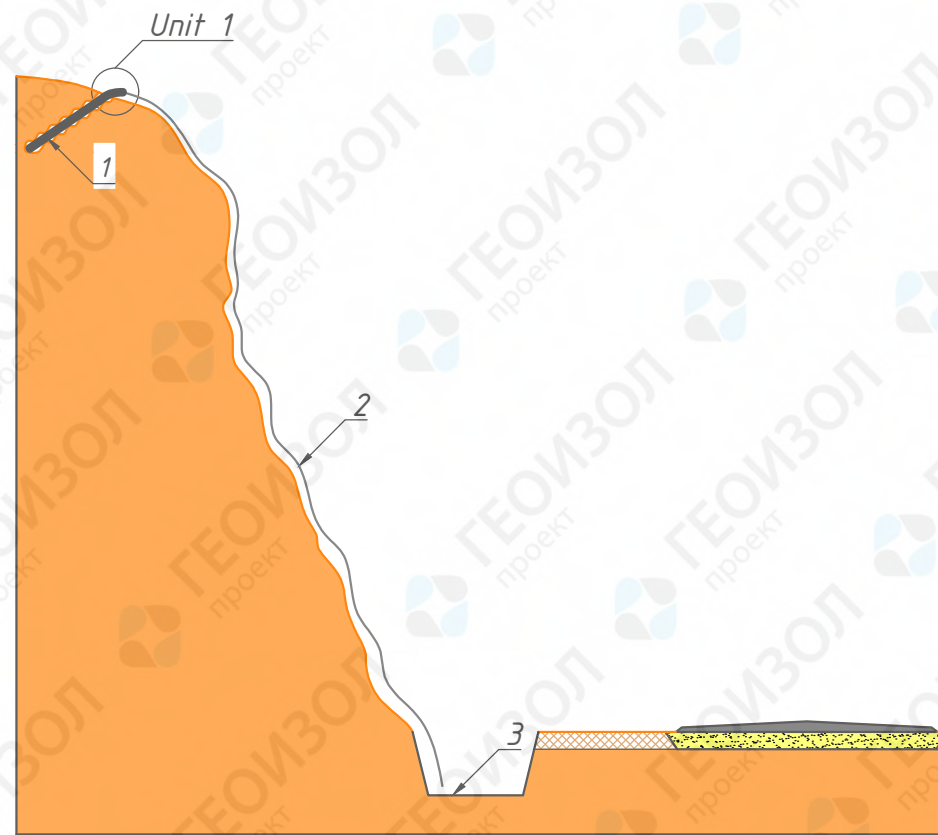

Unit 1

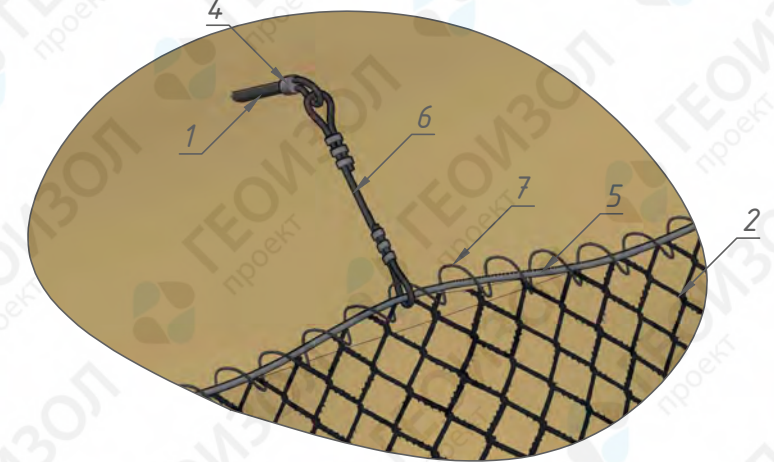

№	Nomination
1	Ground anchor
2	Net curtain
3	Ditch
4	Flexible cap
5	Contour rope
6	Tie
7	Fixture of the curtain to the contour rope

Examples of the existing objects



Purpose:

- To prevent rockfall onto infrastructural facilities.

Operation concept:

Net curtain is installed on the relief of the slope. Ground anchors must be installed on the top of the slope. Contour rope runs through a flexible cap and fixes the curtain. The masses sliding from the slope follow the path set by the curtain and accumulate in the ditch.

Unique features of the standard design solution:

- Simple technology of the works;
- Sets a path of the falling debris;
- Allows to stabilize longer slopes;
- The accumulated debris are removable.

Standard design solutions for engineering protection

Section 4	Rockfall protection, mudslide protection, etc.
Subsection 2	Rockfall protection curtain

General view

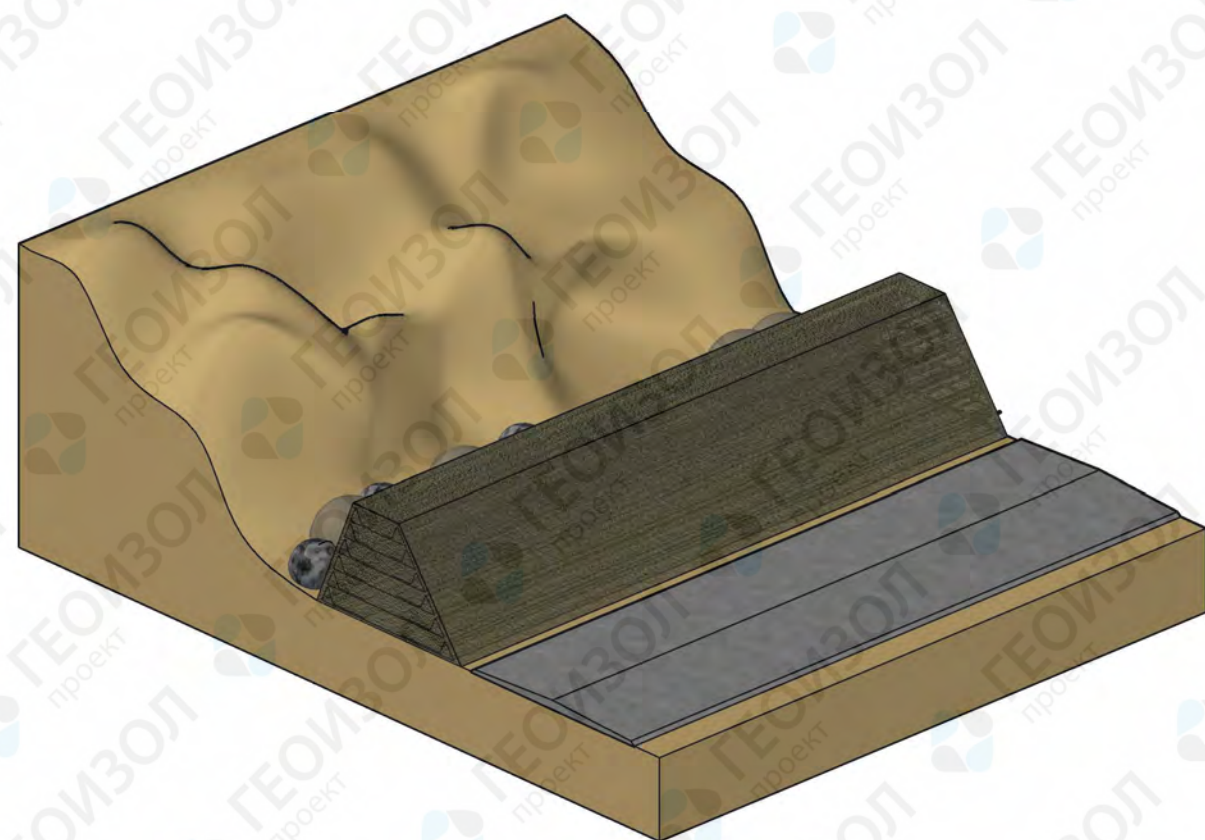

Sectional view

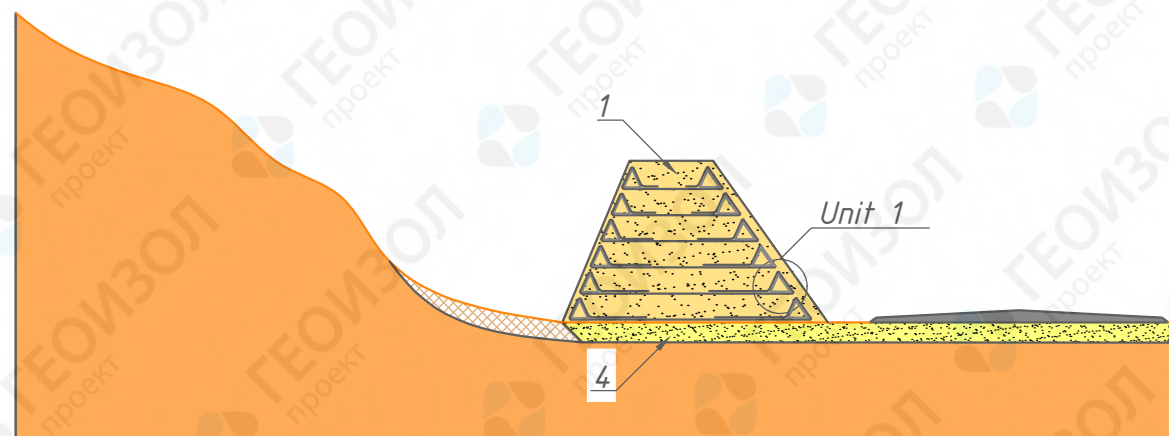

Unit 1

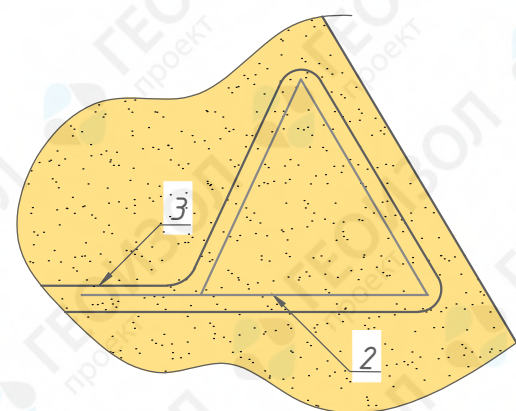

№	Nomination
1	Reinforced ground dam
2	Reinforcement cage
3	Geogrid
4	Basement

Examples of the existing objects



Purpose:

- To stop falling rock debris.

Operation concept:

Basement for a reinforced ground dam is installed. Soil is reinforced by a structure of reinforcement cages wrapped by geogrids. A trapezium-shaped dam is formed from reinforcing elements and soil fill. The dam stops falling debris and prevents them from impact on nearby objects of infrastructure.

Unique features of the standard design solution:

- Simple technology of the works;
- Absorbs the energy of the falling rock debris through deformation of the dam elements;
- Allows to stabilize longer slopes;

Standard design solutions for engineering protection

Section 4	Rockfall protection, mudslide protection, etc.
Subsection 3	Rockfall protection dam

General view

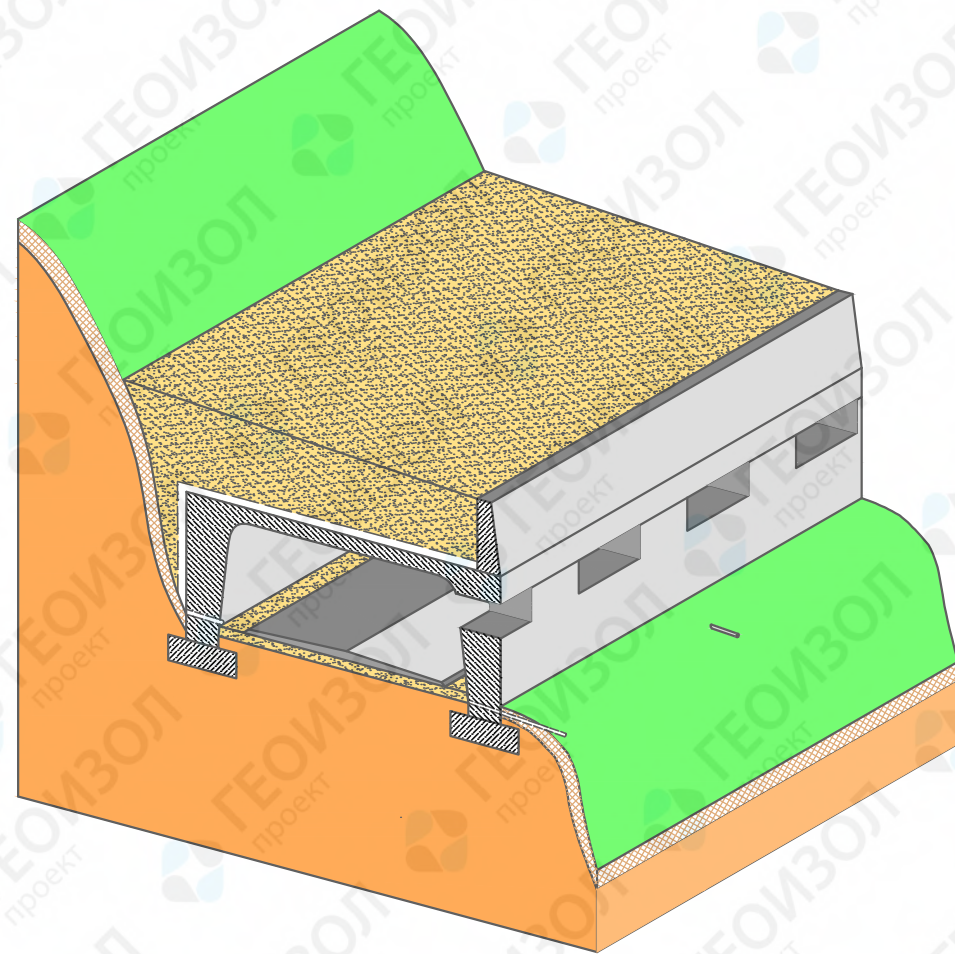

Sectional view

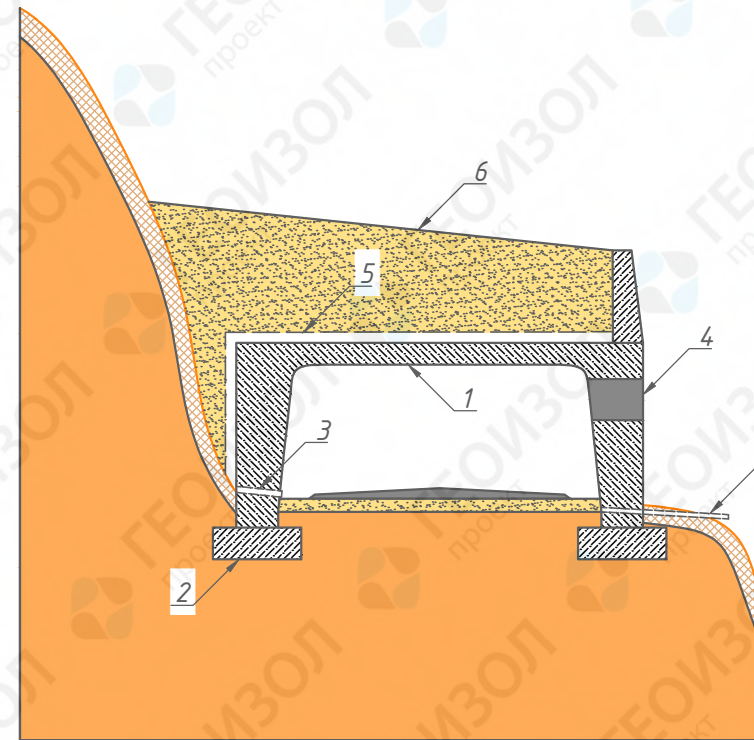

№	Nomination
1	Gallery
2	Foundation
3	Drainage system
4	Opening for lighting and ventilation
5	Waterproofing
6	Protection fill

Examples of the existing objects



Purpose:

- To channel rockfall flow away from infrastructural facilities.

Operation concept:

Installation of a gallery enables foundations of different types, including bored piles. Framing constructed of armored concrete forms an arch above the object of infrastructure. Water isolation in all points of contact with the soil provides removal of moisture from the construction. The covering of the gallery is filled by soil that absorbs the impact force of the falling masses. Elastic properties of the fill can be enhanced by adding rubber parts.

Unique features of the standard design solution:

- Long service life;
- Strength and load resistance;
- Minimizes costs of the infrastructure maintenance.

Standard design solutions for engineering protection

Section 4	Rockfall protection, mudslide protection, etc.
Subsection 4	Rockfall protection gallery

General view

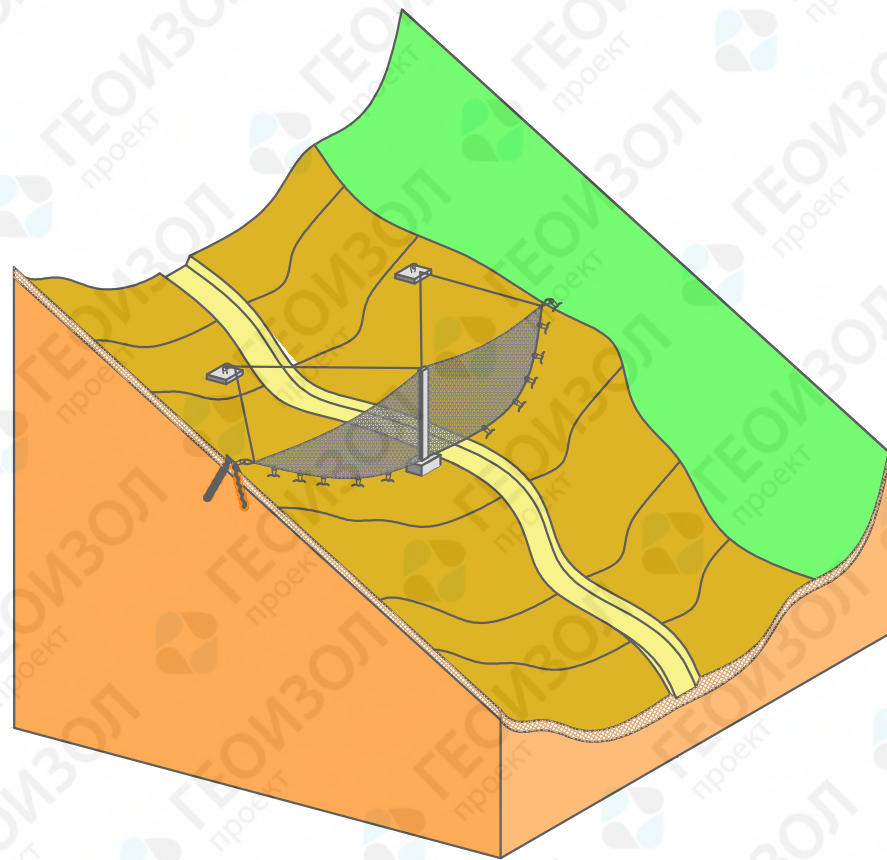

Sectional view

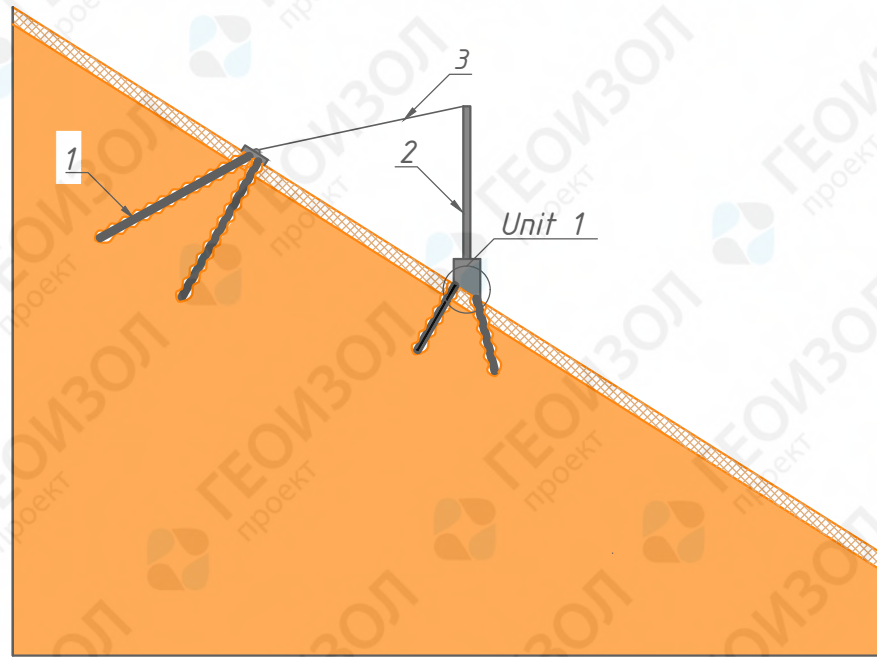

Unit 1

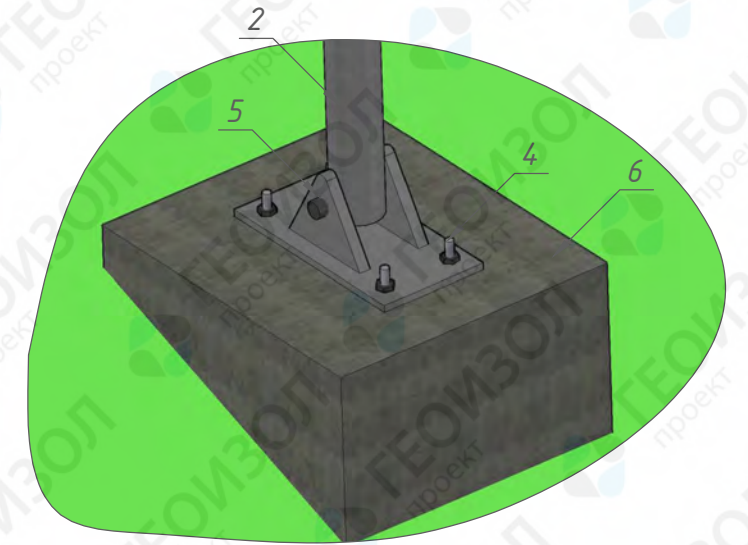

№	Nomination
1	Ground anchor
2	Post
3	Retaining rope
4	Anchor bolt
5	Pin-bearing support part
6	Ground anchor grillage

Examples of the existing objects

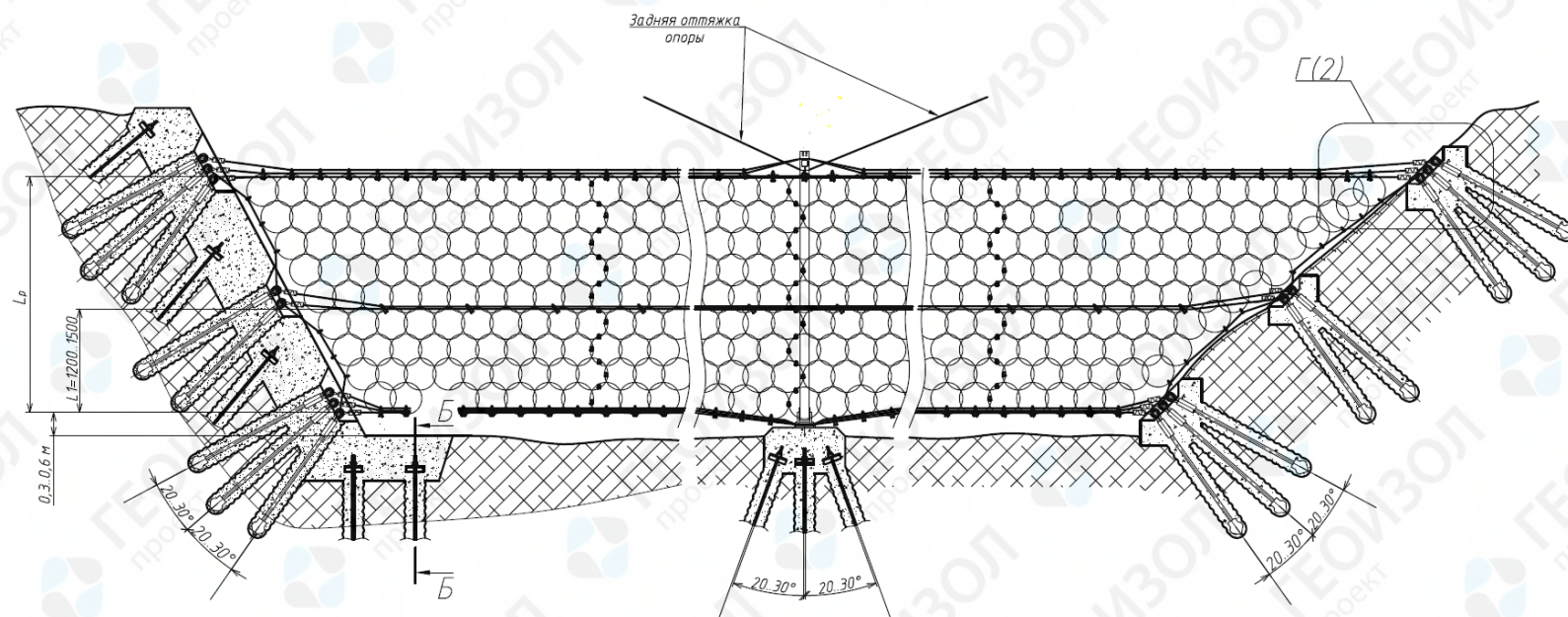

Purpose:

- To stop, separate and hold hard partials of the mudflow.

Operation concept:

Barrier is installed perpendicular to the flow direction. Posts are mounted on a hinged support part to provide rotation in the area of rockfall impact. Retaining ropes hold the posts of the barrier. Ground anchors embed the elements of the barrier into the relief.

Unique features of the standard design solution:

- Endurance and flexibility;
- Simple technology of the works;
- Does not block natural water flow in the channel.

Standard design solutions for engineering protection

Section 4	Rockfall protection, mudslide protection, etc.
Subsection 5	Mudslide protection barrier

General view

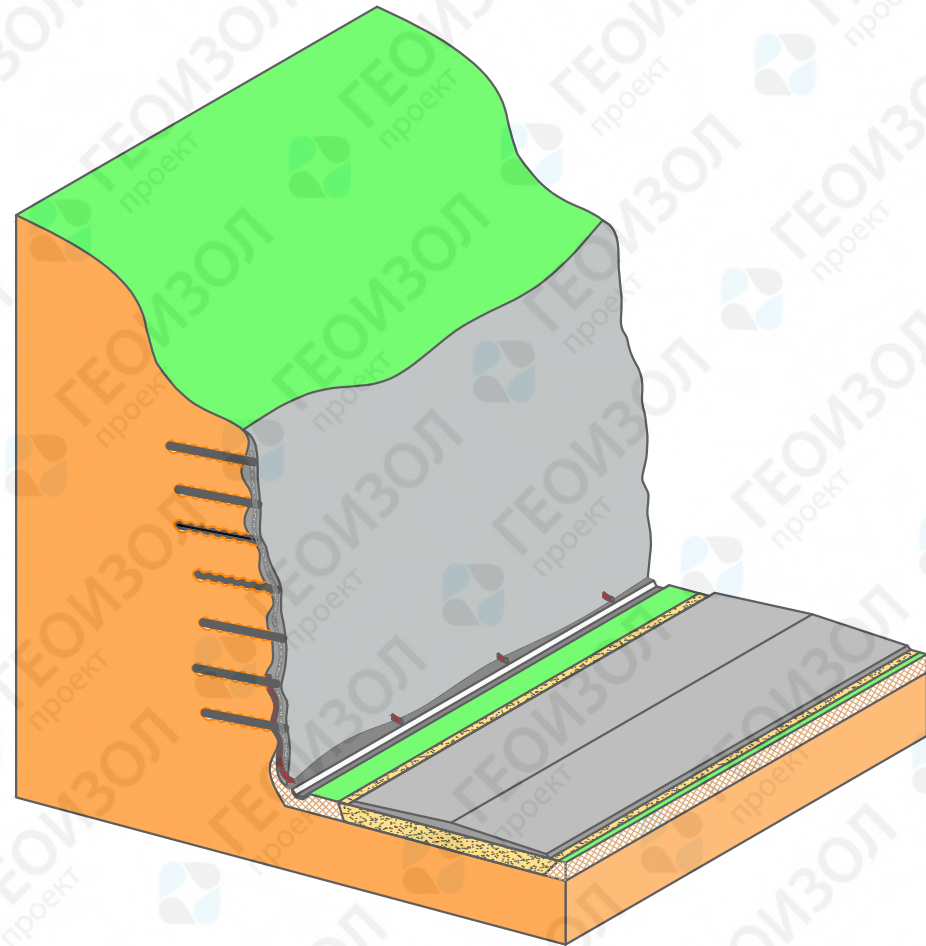

Sectional view

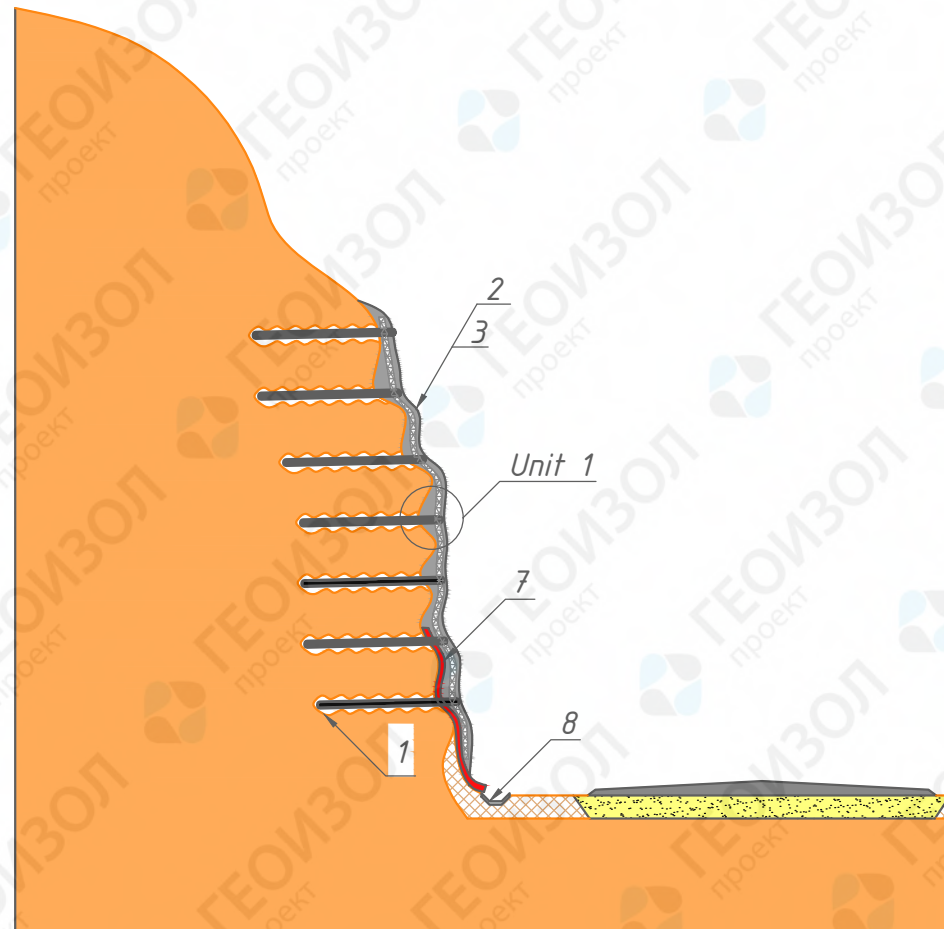

Unit 1

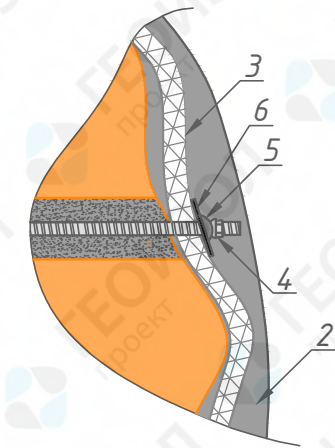

№	Nomination
1	Ground anchor
2	Shotcreting with concrete
3	Net
4	Spherical nut
5	Spherical seat
6	Claw plate
7	Drainage hose
8	Water gutter

Examples of the existing objects



Purpose:

- To strengthen rock masses and prevent rockfall.

Operation concept:

Ground anchors are installed into the rock masses with a stated spacing. Net is fixed to the ground anchor by a spherical nut and pressed to the rock slope by a claw plate. Moisture is removed by drainage pipes collecting water into gutters. Shotcreting is streamlike spraying of concrete to the slope surface. The construction combines properties of reinforcing steel and concrete thus forming durable coating to retain the the slope. The anchors reinforce the soil and retain the shotcreted slope.

Unique features of the standard design solution:

- Consolidates the rock mass;
- Aesthetically and architecturally balanced type of the ready object;
- Solid and homogeneous construction.

Standard design solutions for engineering protection

Section 4	Rockfall protection, mudslide protection, etc.
Subsection 6	Shotcreting of a rock mass

General view

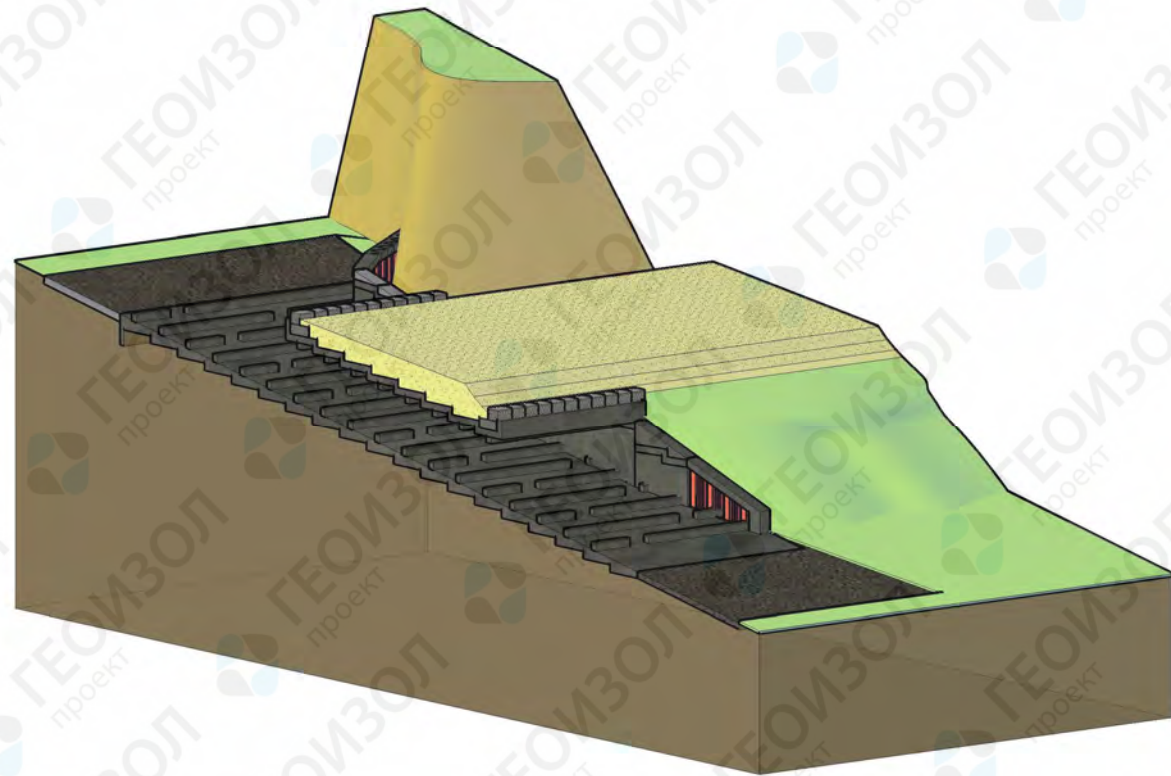

Sectional view

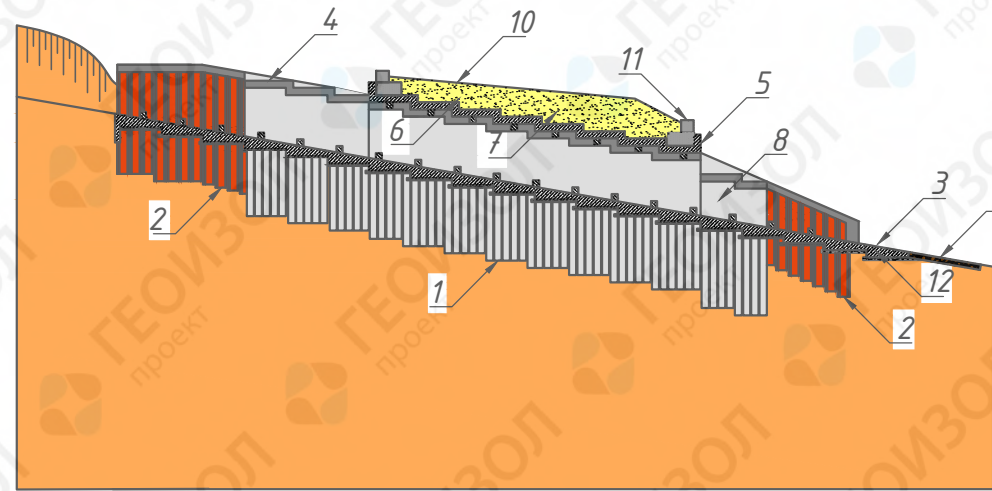

Sectional view of the debris flow channel

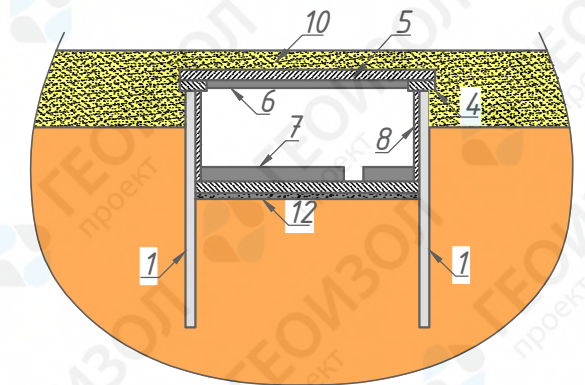

Examples of the existing objects



Purpose:

- To channel debris flow under the infrastructure facilities.

Operation concept:

Piled walls of the debris flow are installed. Pressure wall is installed in order to prevent ground spilling into the cavities between piles. Spandrel beams are joined to the joists to form a rigid structure. The bottom of the debris flow channel of a staircase type has an artificial roughness aimed at reducing velocity of the flow. Head walls are constructed of sheet piles and spandrel beams.

Unique features of the standard design solution:

- Reduces velocity of the flow;
- Allows ongoing landscape works.

№	Nomination
1	Piles
2	Sheet piles
3	Debris flow channel bottom
4	Spandrel beam
5	Debris flow channel closure
6	Joists
7	Artificial roughness (according to the hydraulic calculation)
8	Pressure wall
9	Stabilization of the bed at the outlet
10	Area planing
11	Box-shaped gabion construction
12	Gutter bedding

Standard design solutions for engineering protection

Section 4	Rockfall protection, mudslide protection, etc.
Subsection 7	Debris flow channel of closed type

General view

Sectional view

Sectional view of the debris flow channel

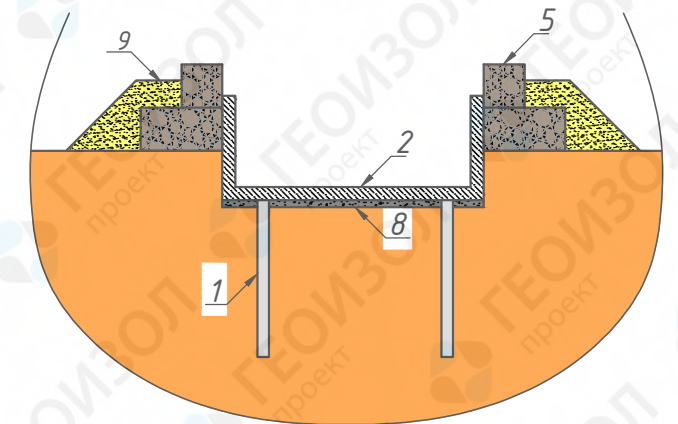
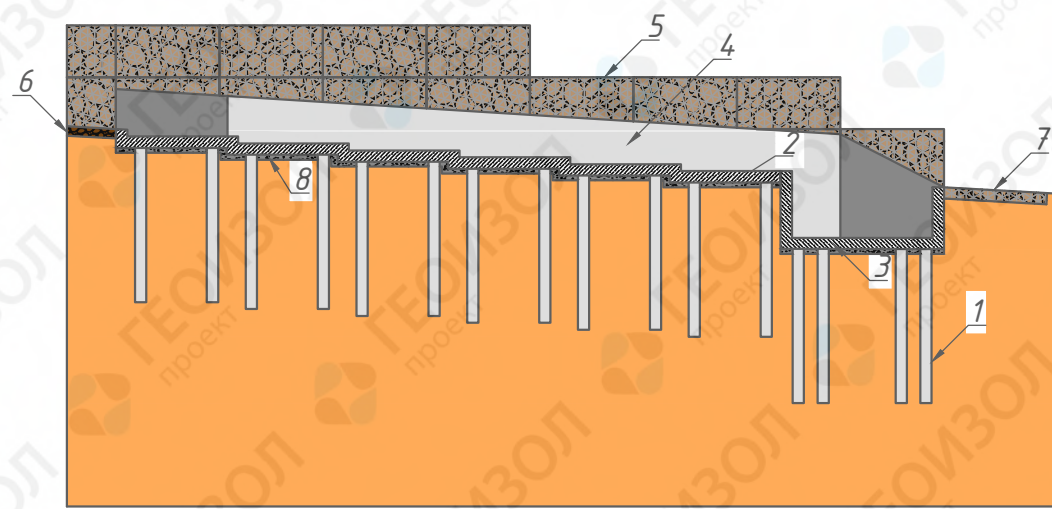

Examples of the existing objects



№	Nomination
1	Piles
2	Debris flow channel bottom
3	Energy dissipator
4	Debris flow channel wall
5	Box-shaped gabions
6	Rockfill blanket
7	Mattress gabion
8	Basement
9	Backfill

Purpose:

- To channel debris flow away from the infrastructure facilities.

Operation concept:

Piled foundation of the debris flow channel is installed. Solid armored concrete construction joints walls and bottom. Box-shaped gabions are installed behind the walls of the channel. The bottom of the debris flow channel of a staircase type has an artificial roughness aimed at reducing velocity of the water flow. The outlet of the structure is equipped with an energy dissipator. The debris flow channel approaches are strengthened by mattress gabions or a rockfill blanket.

Unique features of the standard design solution:

- Allows to change the path of a debris flow.

Standard design solutions for engineering protection	
Section 4	Rockfall protection, mudslide protection, etc.
Subsection 8	Debris flow channel of open type



Section 5
Strengthening soft and specific
grounds

General view

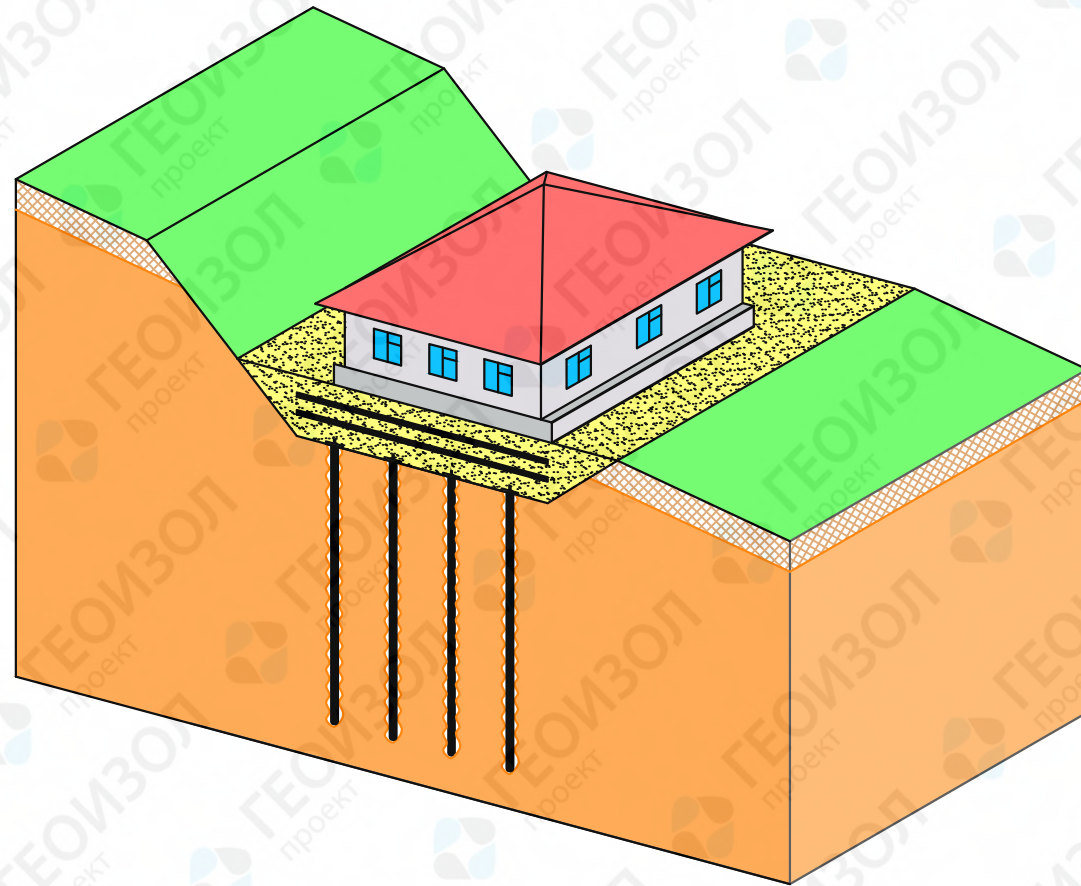

Sectional view

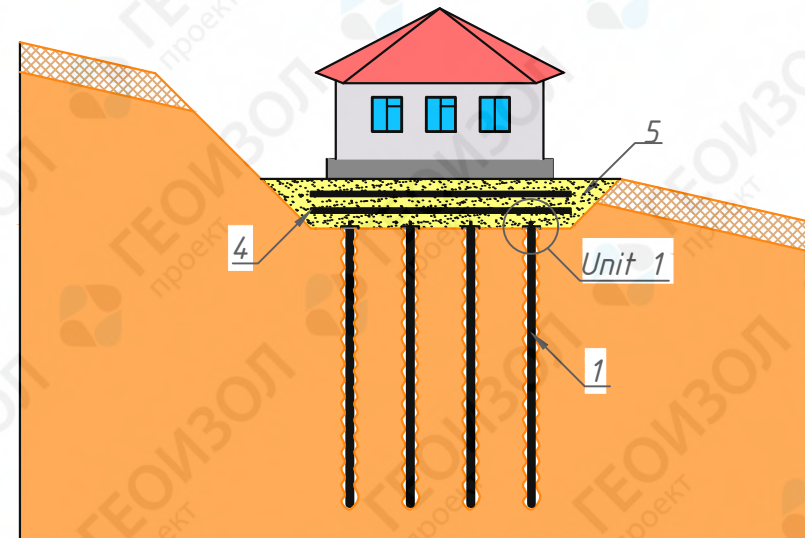

Unit 1

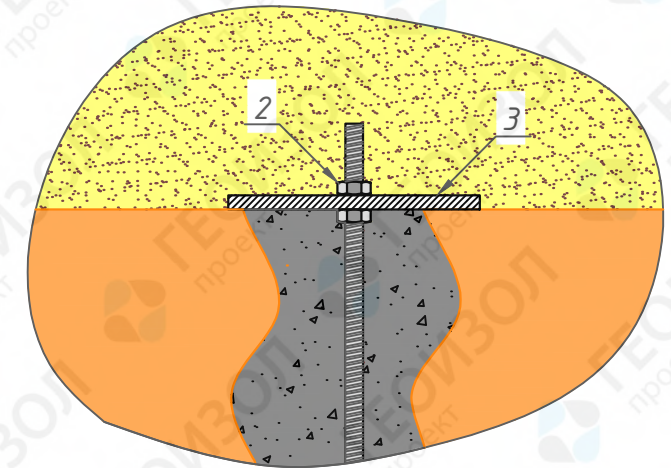

№	Nomination
1	Grout-injected piles
2	Nut
3	Plate
4	Geogrid
5	Soil fill

Examples of the existing objects

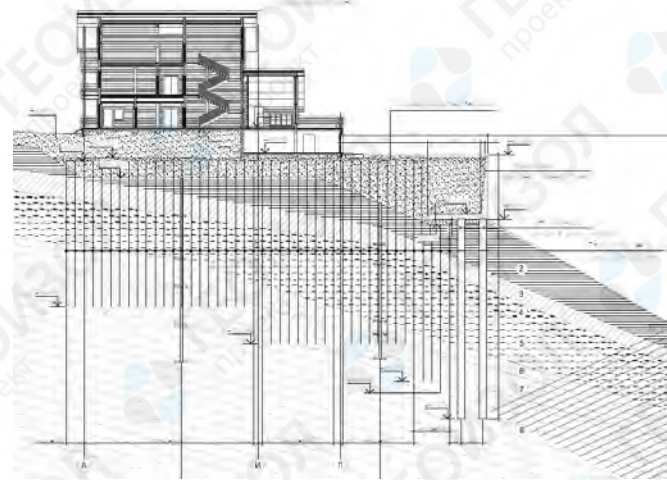

Purpose:

- To strengthen basement of the construction.

Operation concept:

A pit for future grillage is dug. Bored piles with fixed position are installed according to calculations. The pit is backfilled by firm soil reinforced by several layers of geogrids. The grillage construction distributes evenly the pressure of the building to the soil. The bored piles provide the foundation with required robustness.

Unique features of the standard design solution:

- Simple technology of the works.

Standard design solutions for engineering protection

Section 5	Strengthening soft and specific grounds	
Subsection 1	Grout-injected piles on flexible grillage	

General view

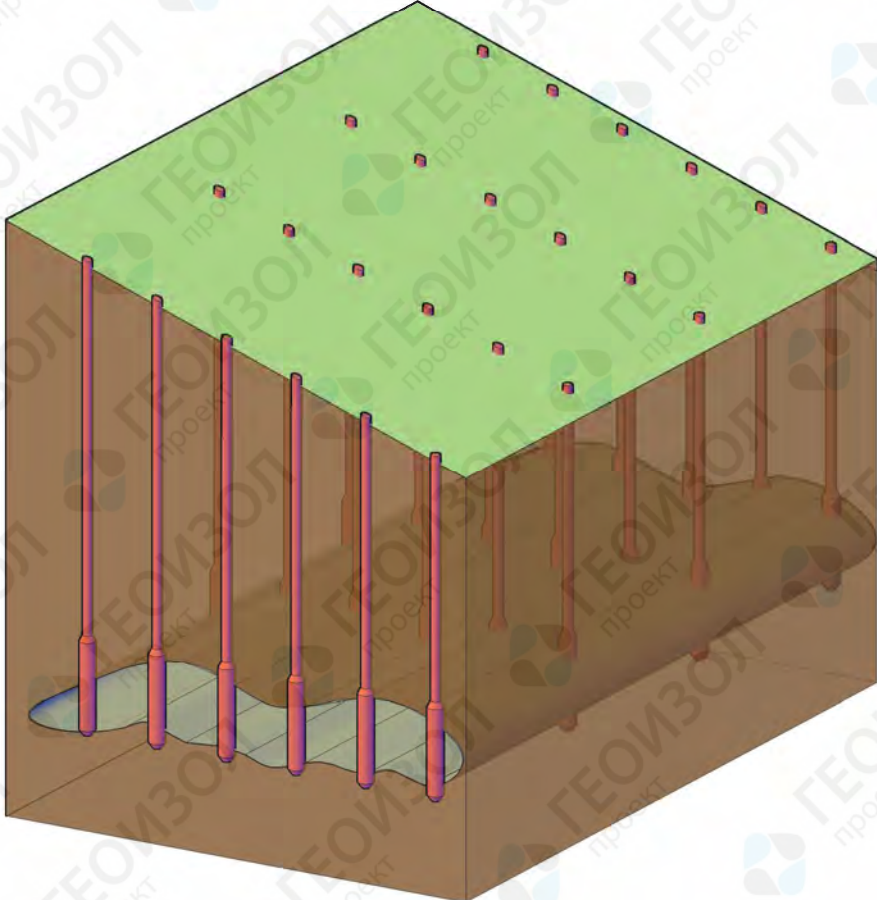

Sectional view

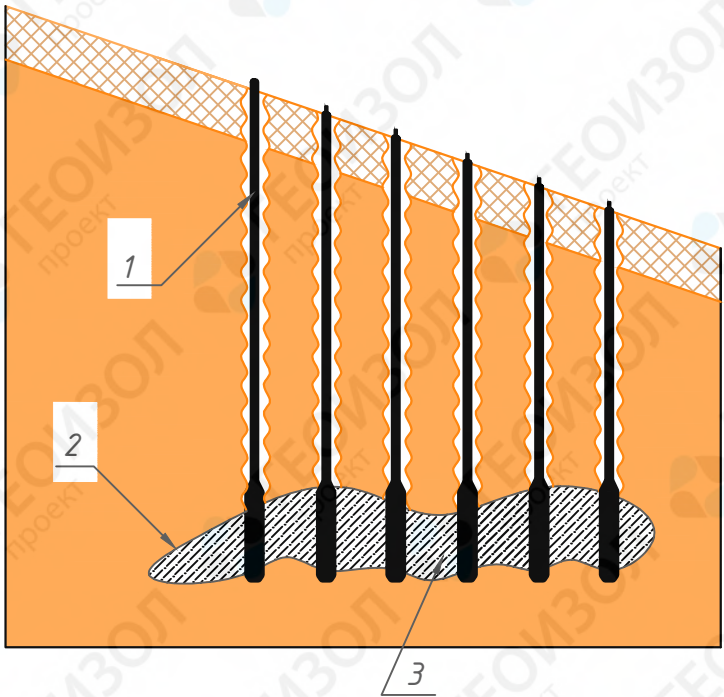

№.	Nomination
1	Grout-injected well
2	Cavern
3	Injected filler

Construction process

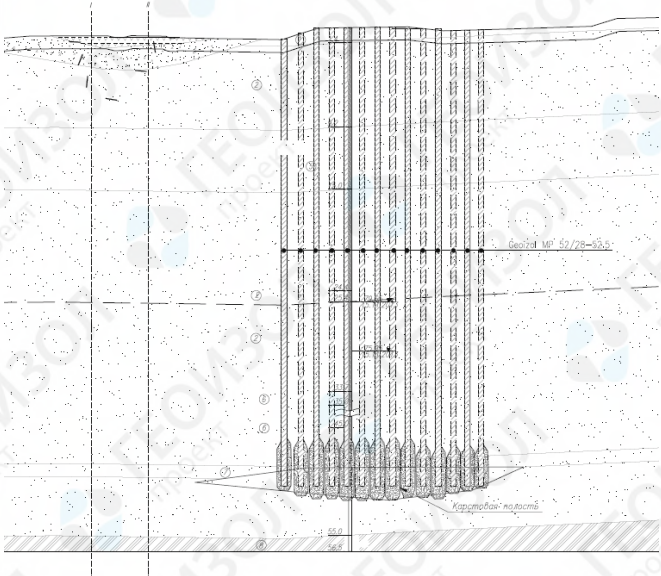

Purpose:
- To fix the cavern.

Operation concept:
Bored wells are installed through cavern. Concrete grout is discharged under pressure into the cavity and fills all the space. The bored wells technology allows to prepare a stable foundation for a future building.

Unique features of the standard design solution:
- Simple technology of the works;
- Allows construction on karst hazard areas.

Standard design solutions for engineering protection		
Section 5	Strengthening soft and specific grounds	
Subsection 2	Cavern filling	

General view

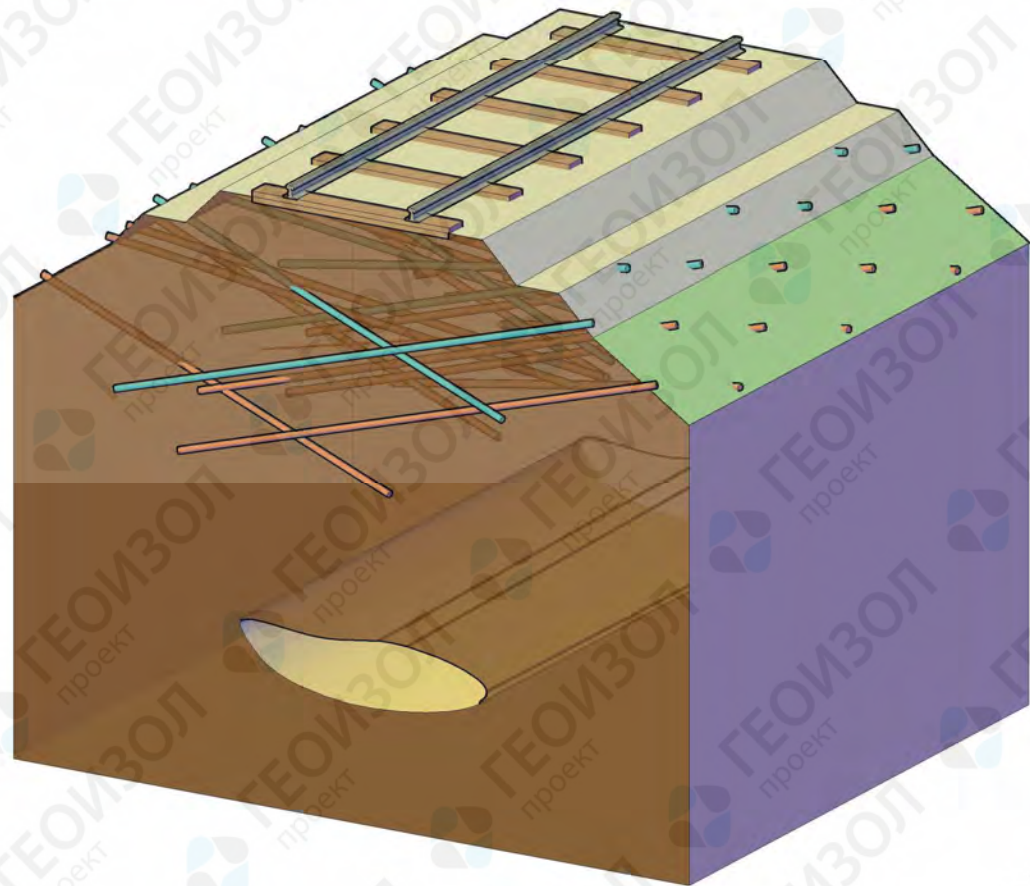

Sectional view

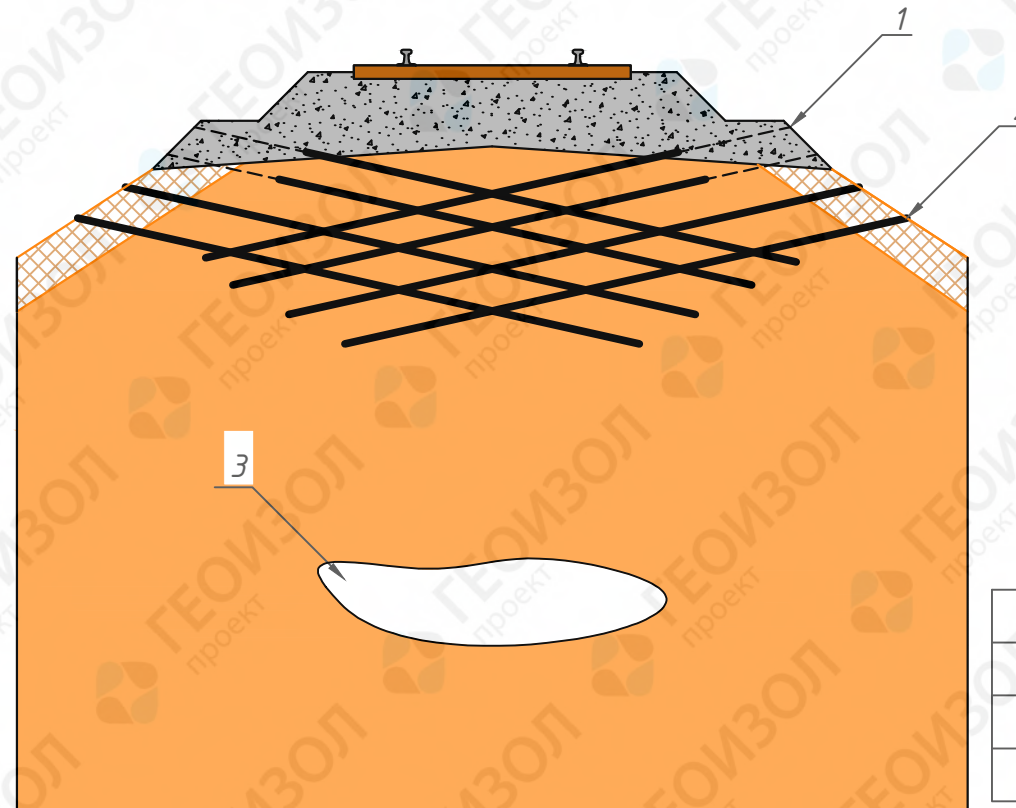

№	Nomination
1	Soil nail with retrievable part
2	Soil nail
3	Theoretical cavern

Construction process



Purpose:

- To prevent effect of the cavern development.

Operation concept:

Soil nails are installed into the earth bed of an infrastructure object. The technology implies installing the nails at an angle with edges crossed. This method is aimed at preparing a robust foundation able to prevent the earth bed from failure in case of a developed cavern.

Unique features of the standard design solution:

- Simple technology of the works;
- Allows construction without disassembling the object of infrastructure.

Standard design solutions for engineering protection

Section 5	Strengthening soft and specific grounds
Subsection 3	Soil reinforcement, cavern-related mitigation

General view

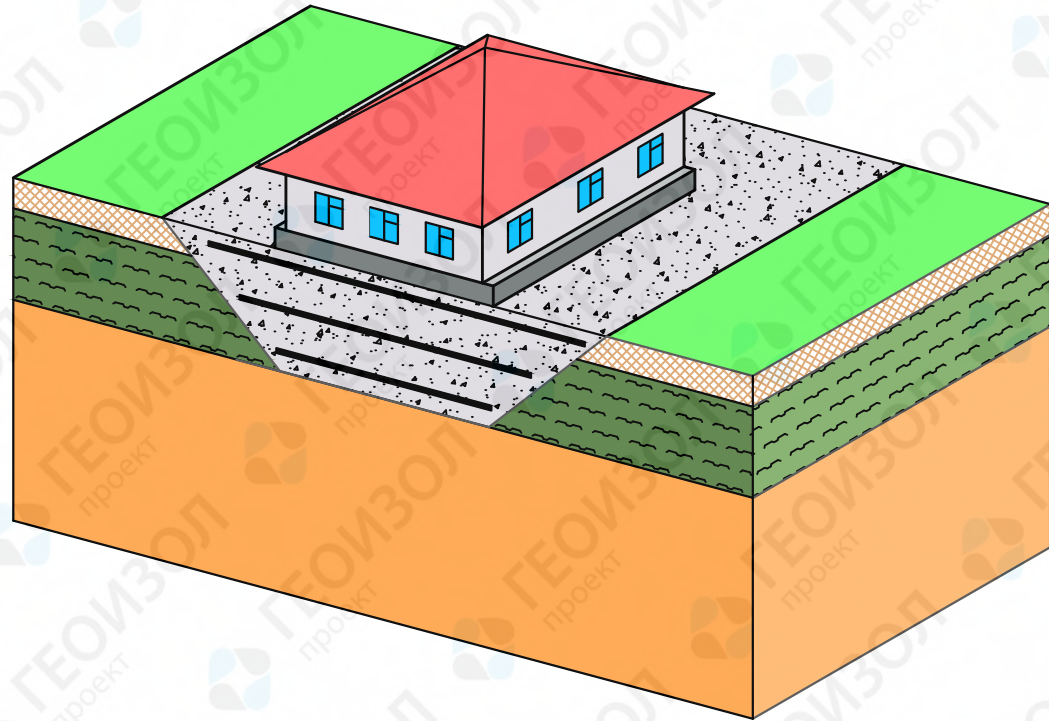

Sectional view

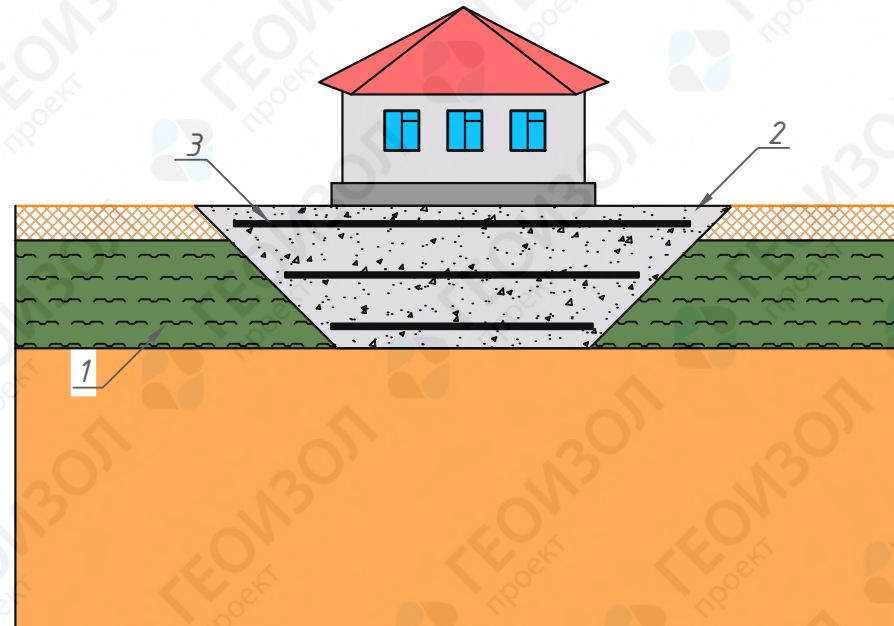

№	Nomination
1	Weak soil
2	Pit digging followed by solid soil refilling
3	Geogrid

Construction process



Purpose:

- Foundation and substructure works in hazard geological conditions.

Operation concept:

Weak soil layers are excavated to a layer of higher firmness. The pit is backfilled with solid soil and reinforced by geogrids. Implementation of the geogrids enhances properties of the backfill and prevents soil movements under loads.

Unique features of the standard design solution:

- Allows to exclude piled foundation;
- Enhances draining characteristics of the adjacent soils;
- Creates buildable sites.

Standard design solutions for engineering protection

Section 5	Strengthening soft and specific grounds	<p>ГЕОИЗОЛ проект</p>
Subsection 4	Replacement of the weak soil	

General view

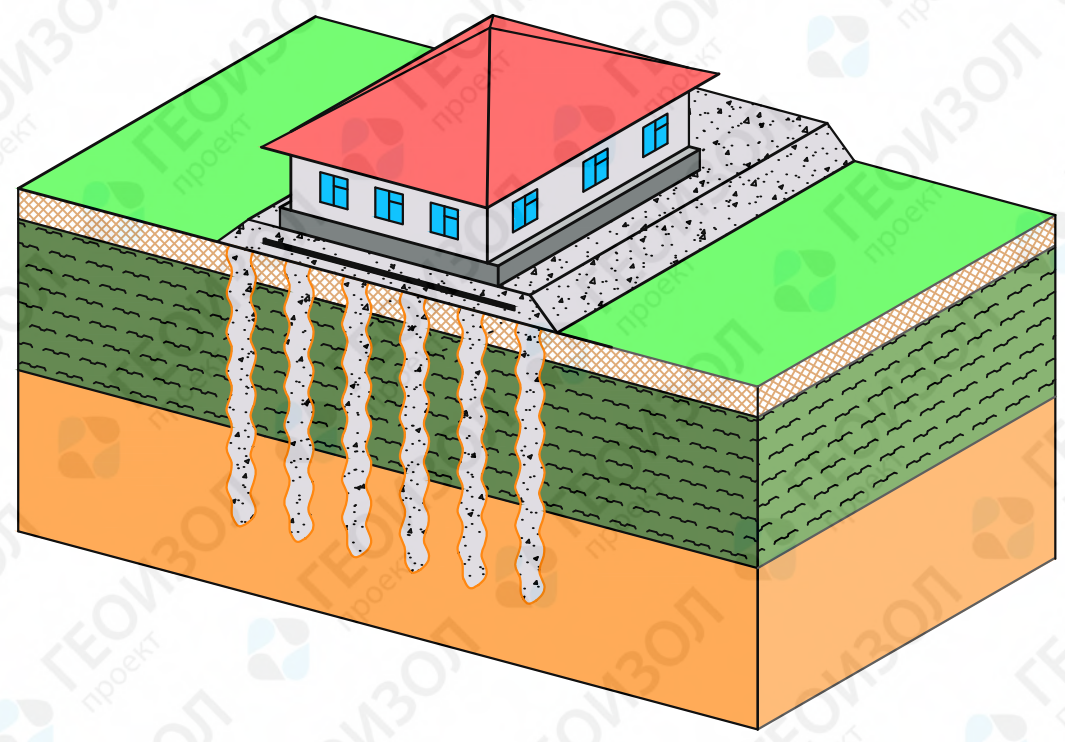

Sectional view

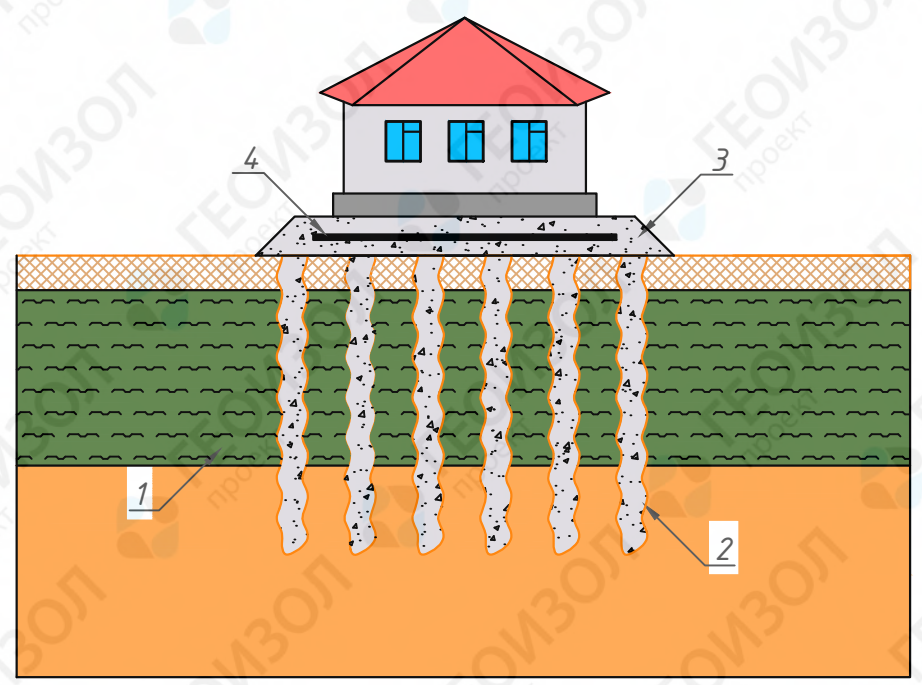

№	Nomination
1	Weak soil
2	Crushed-stone piles
3	Flexible grillage
4	Geogrid

Constructing crushed-stone piles by vibro flotation

Construction process

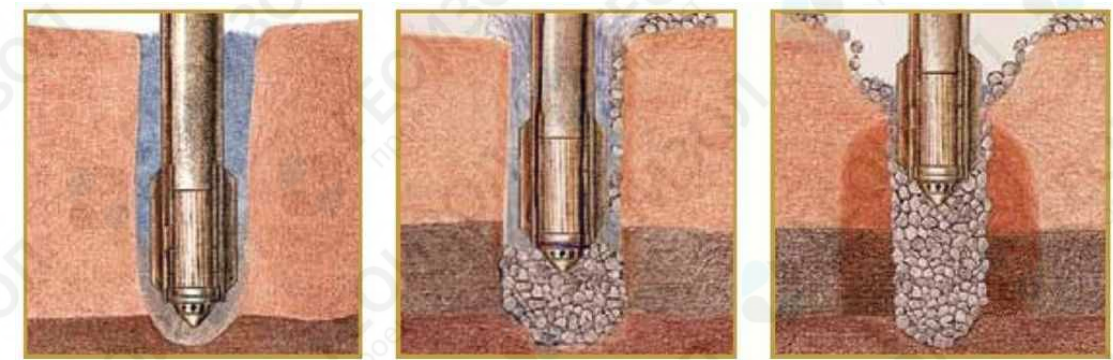

Purpose:
 - Foundation and substructure works in hazard geological conditions.

Operation concept:
 Crushed-stone piles are installed by vibroflot technique. The piles work as vertical drains and reduce overburden pressure that leads to soil weakening. Crushed-stone piles enhance properties of the soil and helps to remove excess of moisture.

Unique features of the standard design solution:
 - Reduced settling of nearby objects;
 - Allows high embankments before significant settlement caused by consolidation of foundation soils occurs.
 - Prevents drastic drop in stress-related characteristics of the soil during earthquakes.

Standard design solutions for engineering protection		
Section 5	Strengthening soft and specific grounds	
Subsection 5	Ground improvement by means of stone columns	

General view

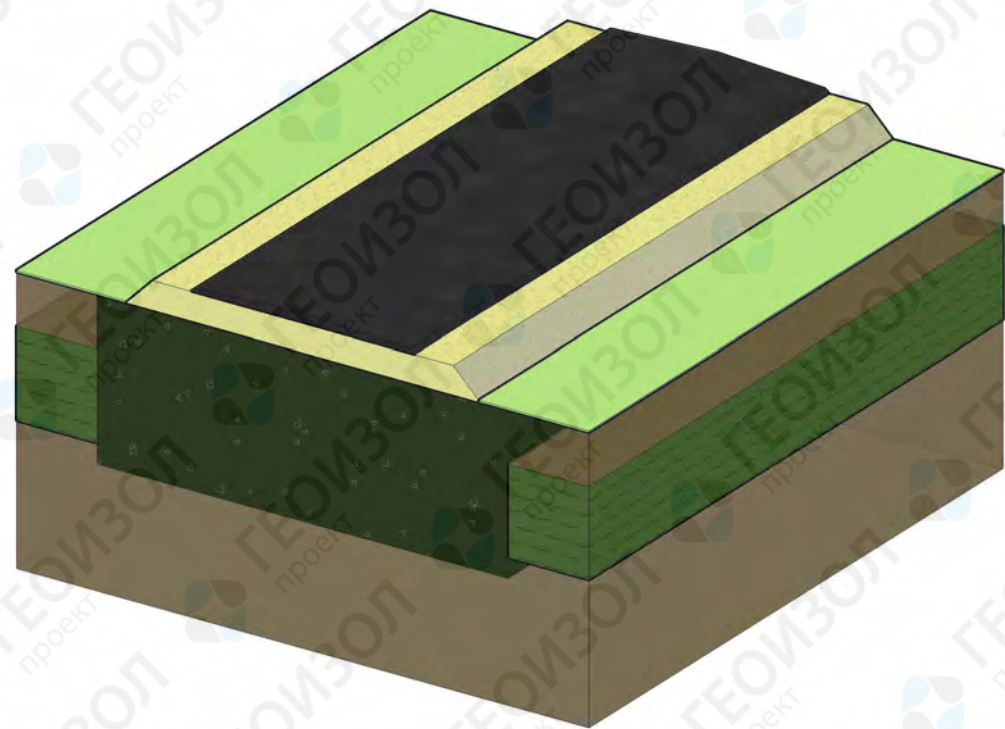

Sectional view

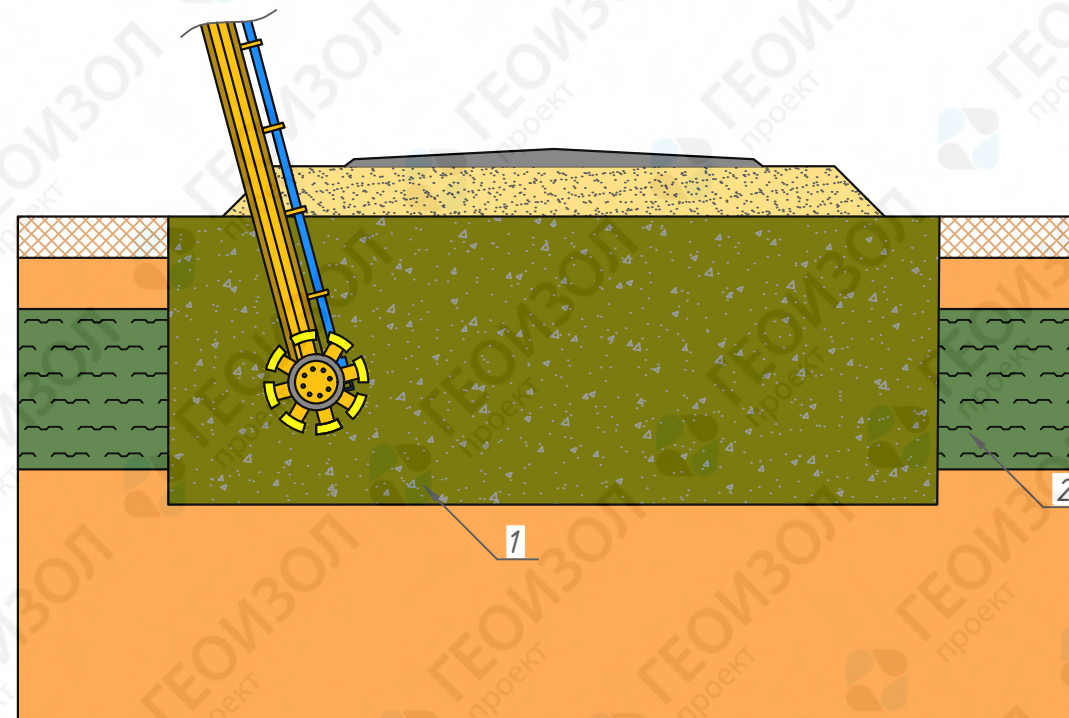

Equipment

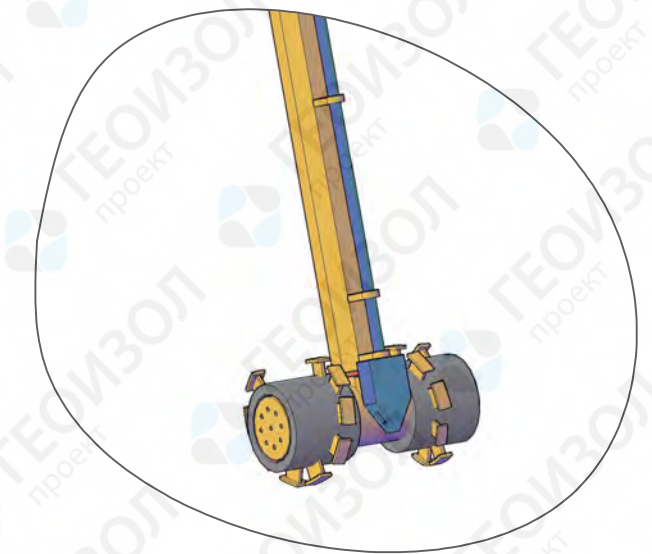

Construction process



№	Nomination
1	Weak soil stabilized by the binding agent
2	Weak soil

Purpose:

- Foundation and substructure works in hazard geological conditions.

Operation concept:

The equipment is dipped into weak soil. The equipment injects a binding agent into the soil and mixes the required amount of soil. The binding agent stabilizes the weak soil and enhances its properties.

Unique features of the standard design solution:

- Excludes earthwork operations;
- Allows to strengthen localized areas.

Standard design solutions for engineering protection

Section 5	Strengthening soft and specific grounds
Subsection 6	Stabilizing soil by binding agent



Section 6
Permafrost grounds protection

General view

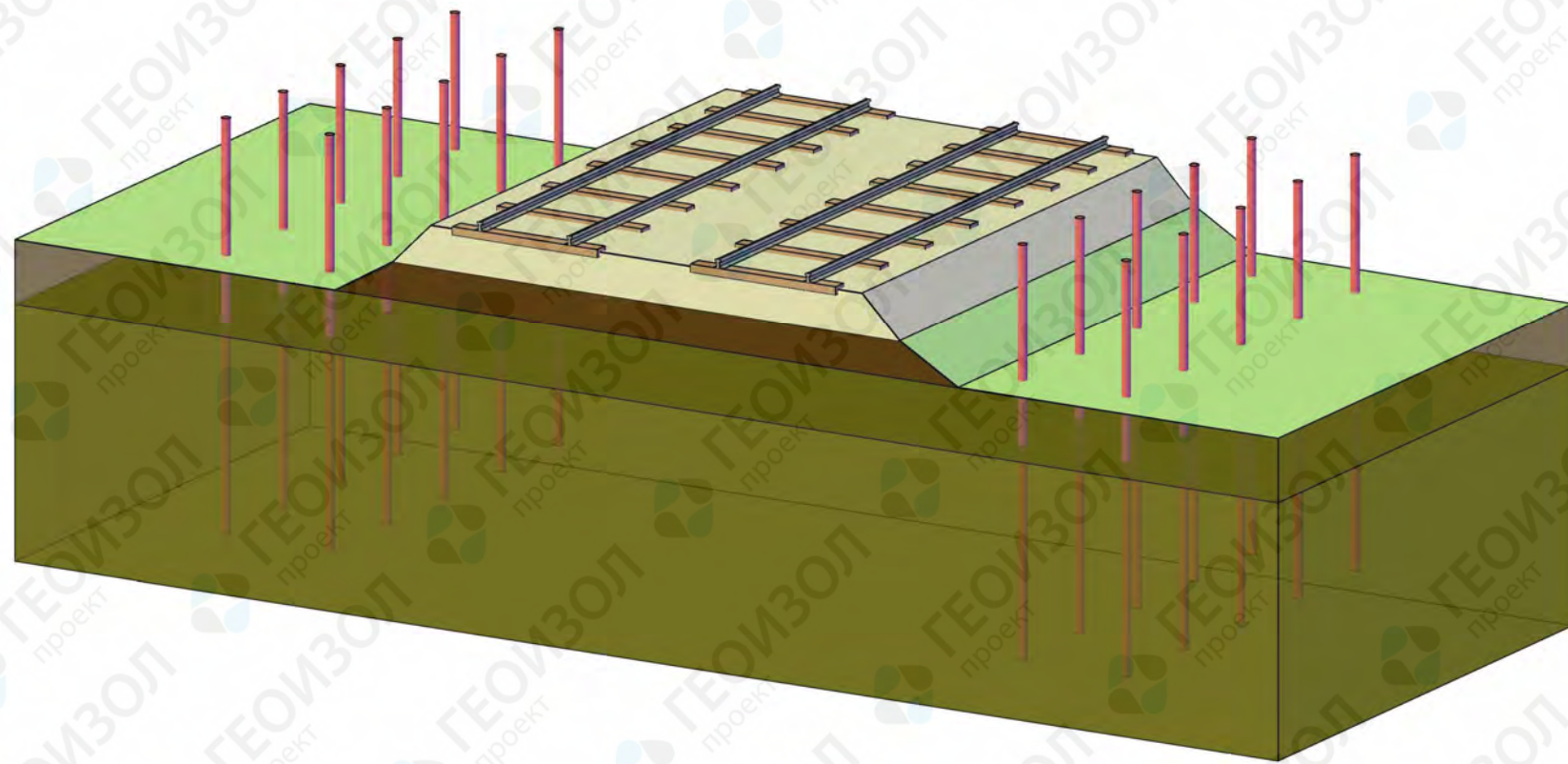

Sectional view

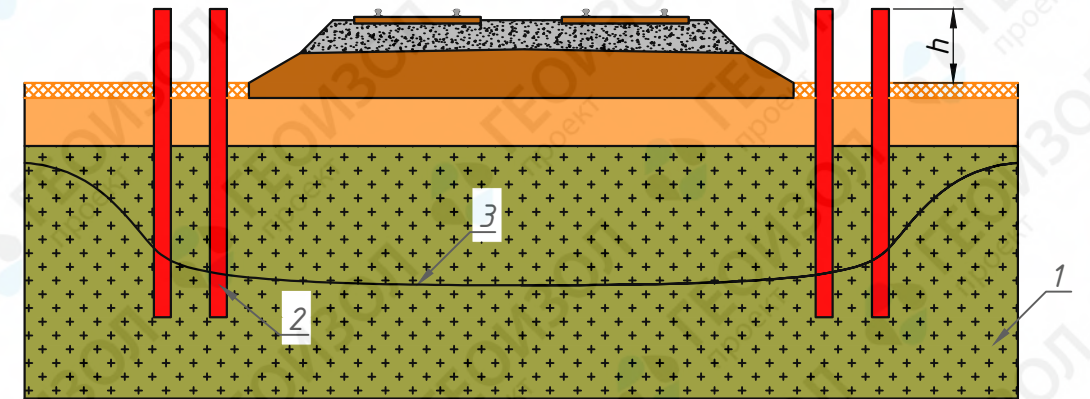

№	Nomination
1	Permafrost soil
2	Thermal stabilizing
3	Possible thawing line of the permafrost soil

Examples of the existing objects



Purpose:

- To maintain permafrost in foundations and substructures.

Operation concept:

In the setting of permafrost soil thawing is inevitable in the process of construction or maintaining objects. In order to prevent losing foundation stability thermal stabilizing is installed. When the temperature drops, the heat carrier circulating in the thermal stabilizing cools down the permafrost.

Unique features of the standard design solution:

- Does not require electric energy;
- Simple technology of the works;
- Allows to stabilize longer sites.

Standard design solutions for engineering protection

Section 6	Permafrost grounds protection	<p>ГЕОИЗОЛ проект</p>
Subsection 1	Thermal stabilizing	

Section 7
Avalanche protection

General view

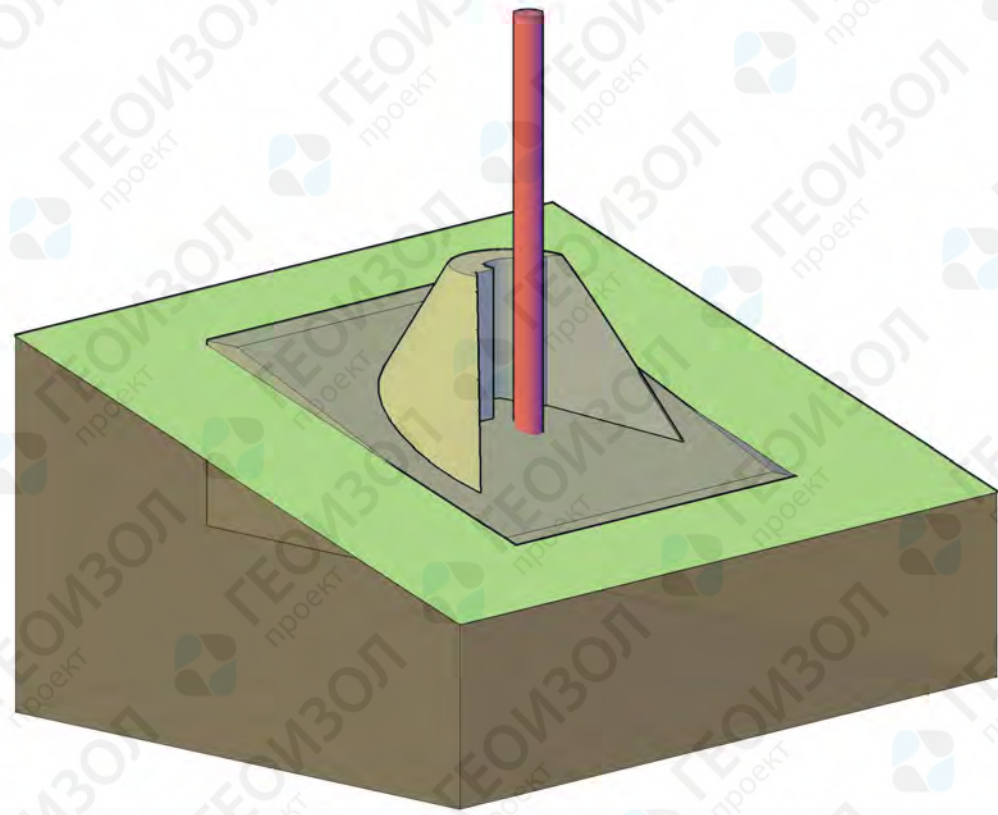

Sectional view

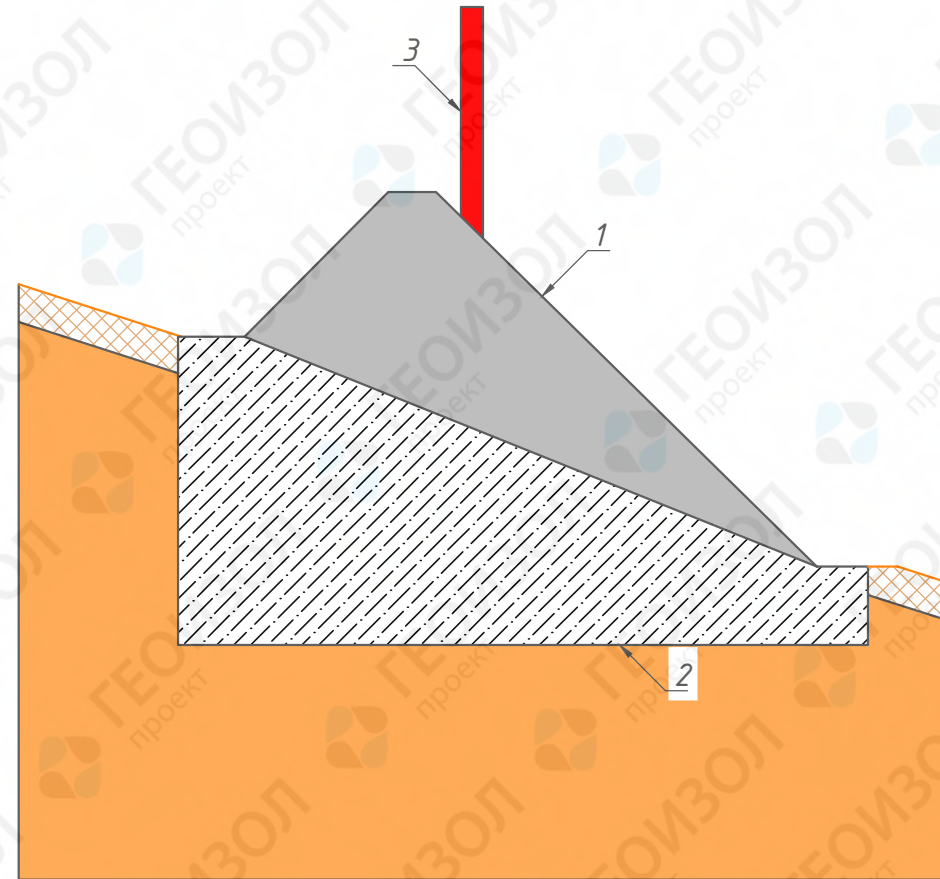

№	Nomination
1	Avalanche-breaker
2	Foundation
3	Protected construction

Examples of the existing objects



Purpose:

- To protect constructions from impacts of debris flow.

Operation concept:

Foundation and the body of armored concrete avalanche-breaker are installed. Massive construction secures its functionality on exposure to avalanche impact. The conic frustum shape of the avalanche-breaker smoothly channels moving snow flows away from the object.

Unique features of the standard design solution:

- Simple technology of the works;
- High strength properties.

Standard design solutions for engineering protection

Section 7	Avalanche protection	<p>ГЕОИЗОЛ проект</p>
Subsection 1	Massive avalanche-breaker	

General view

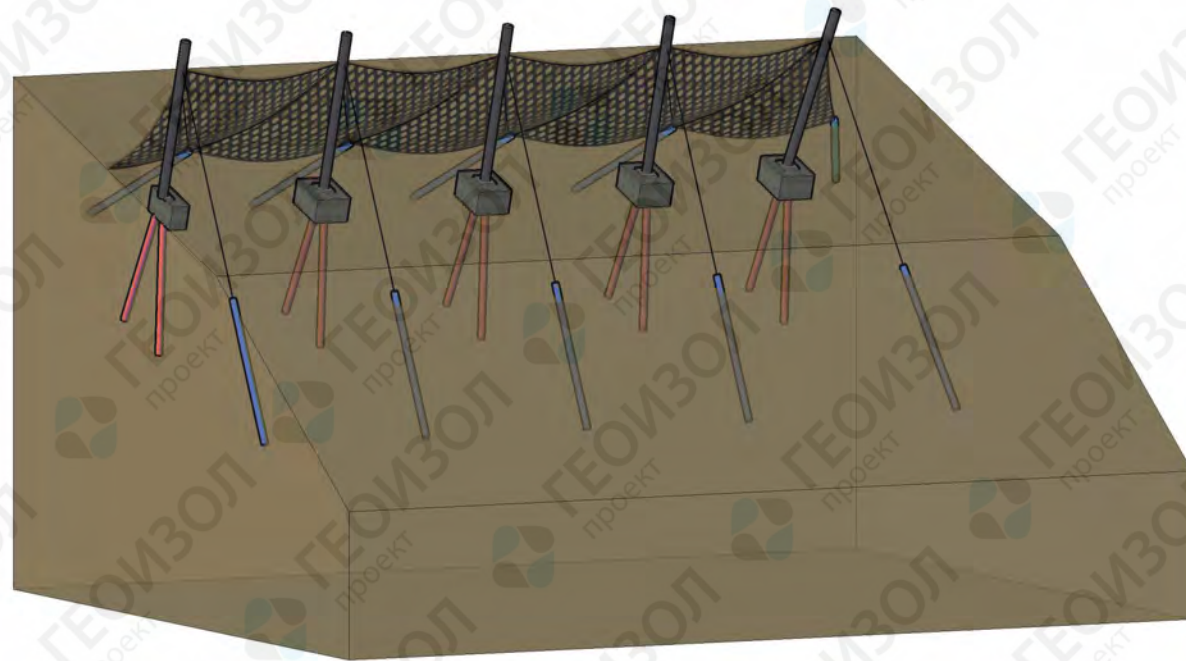

Sectional view

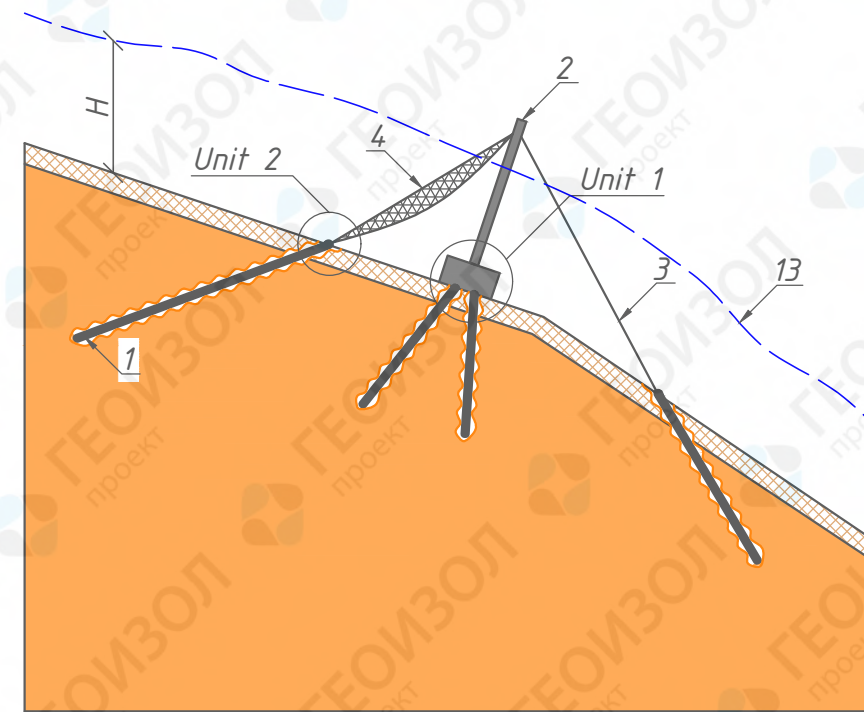

H - Design data of snow cover depth

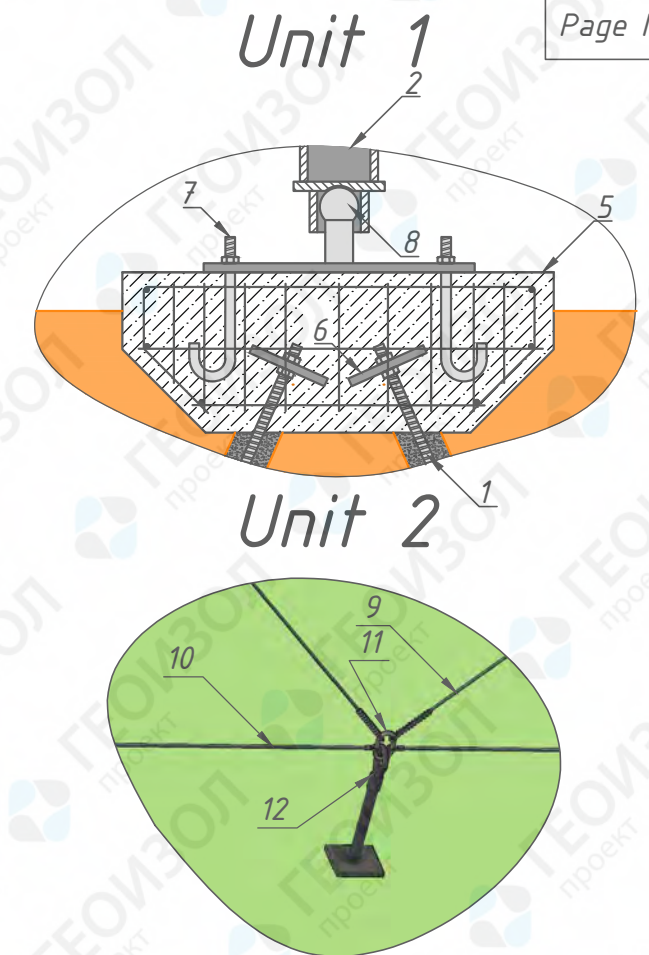

Purpose:

- To protect constructions from of avalanches.

Operation concept:

Flexible snow bridge is installed perpendicular to slope in the area of possible formation of avalanches. The bridges work in the places of static loads and retain the snow masses preventing avalanches. The bridge embedment is secured by ground anchors consolidated into grillage.

Unique features of the standard design solution:

- Prevents avalanches;
- Snow retention ring net resistant to rockfall-caused loads;
- Resistant to dynamic loads.

№	Nomination
1	Ground anchor
2	Post
3	Retaining rope
4	Net
5	Ground anchor grillage
6	Anchor plate
7	Anchor bolt
8	Hinge pin
9	Adjustable retaining ropes
10	Lower bearing rope
11	Rope loop
12	Ground anchor connection to the rope loop
13	Snow cover border

Examples of the existing objects



Standard design solutions for engineering protection

Section 7	Avalanche protection
Subsection 2	Flexible snow bridges

General view

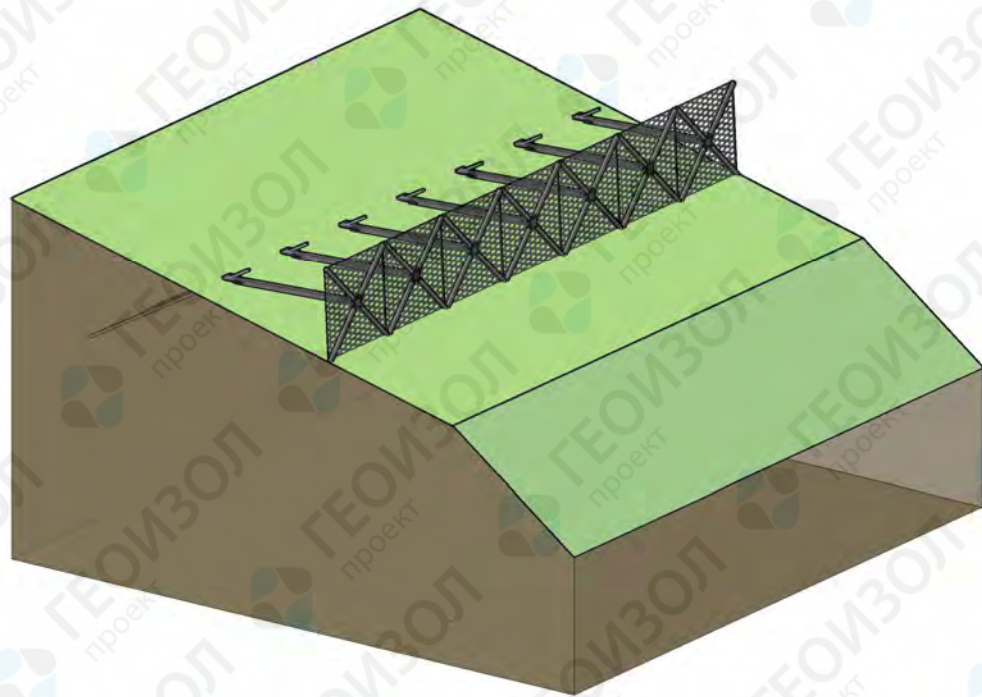

Sectional view

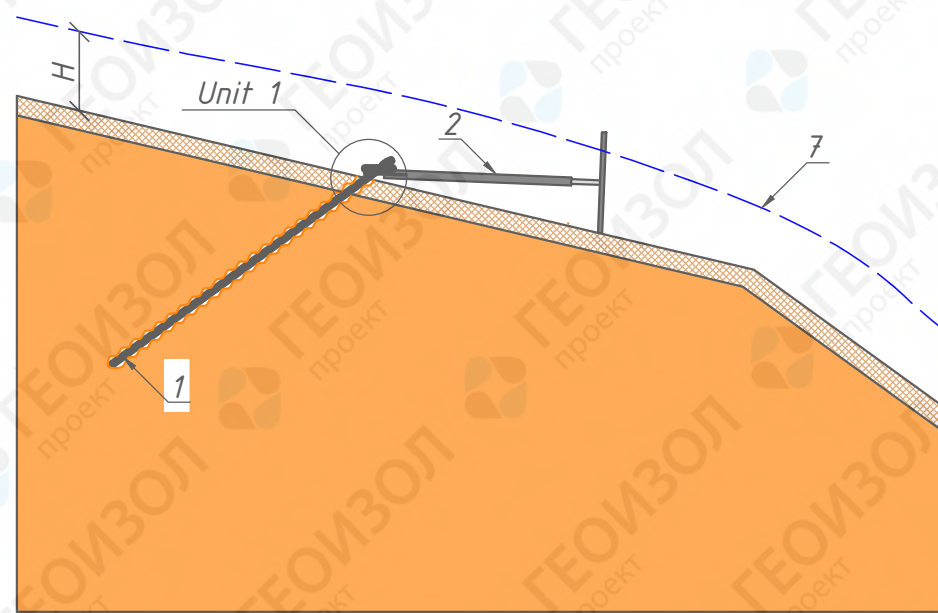

H - Design data of snow cover depth

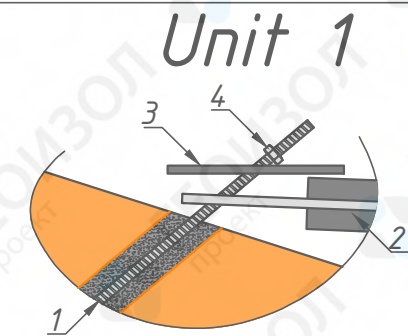

Snow umbrella

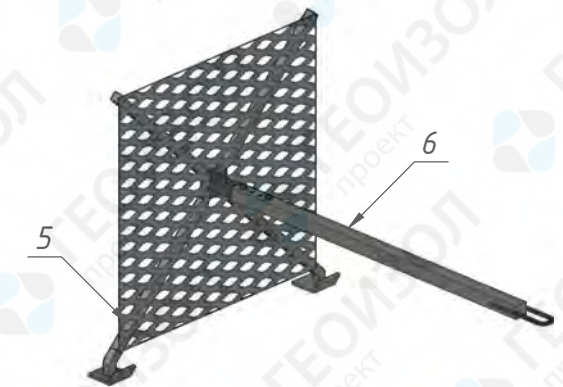

Examples of the existing objects



№	Nomination
1	Ground anchor
2	Snow umbrella
3	Plate
4	Nut
5	Net panel
6	Telescope boom
7	Snow cover border

Purpose:

- To protect infrastructure facilities from avalanches.

Operation concept:

Installation of snow umbrella implies installing ground anchors embedding it to the terrain. The umbrellas are installed perpendicular to slope to retain snow masses. Telescope boom allows changing the umbrella extension and setting the construction individually for every slope. Module-based construction allows to vary numerous configurations.

Unique features of the standard design solution:

- Features properties of flexible snow bridges;
- Simple technology of the works;
- Allows seasonal demolition.

Standard design solutions for engineering protection

Section 7	Avalanche protection
Subsection 3	Snow umbrellas

General view

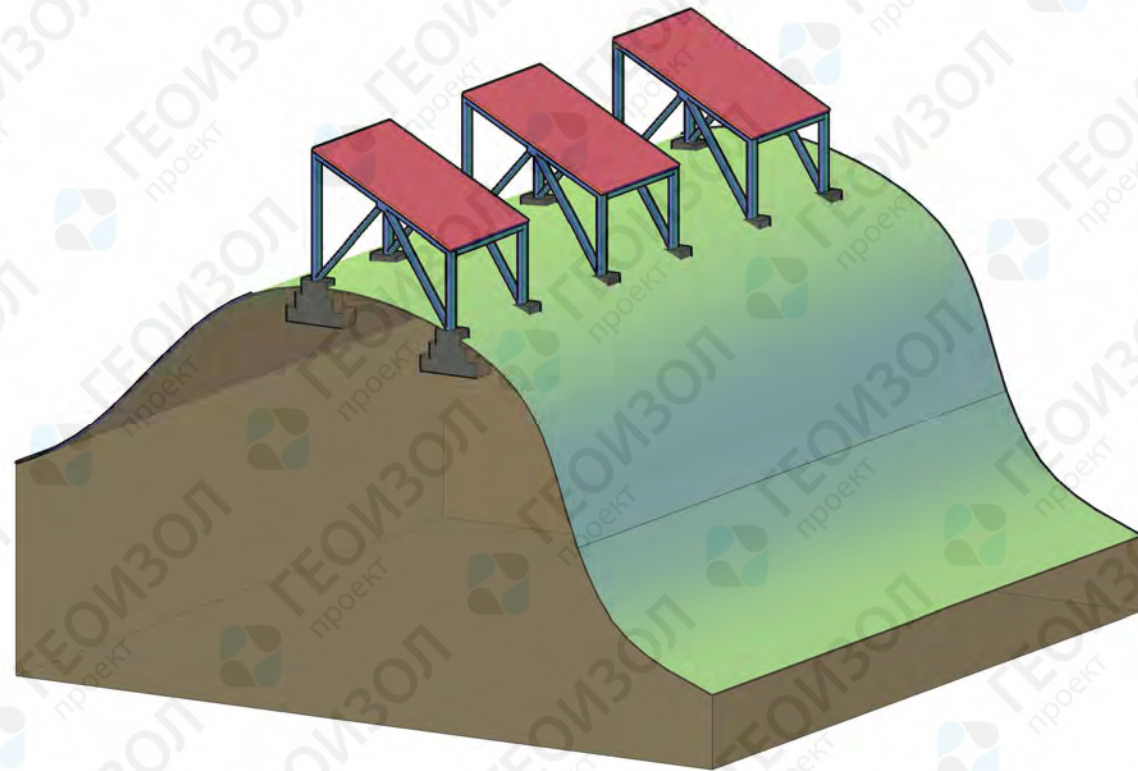

Sectional view

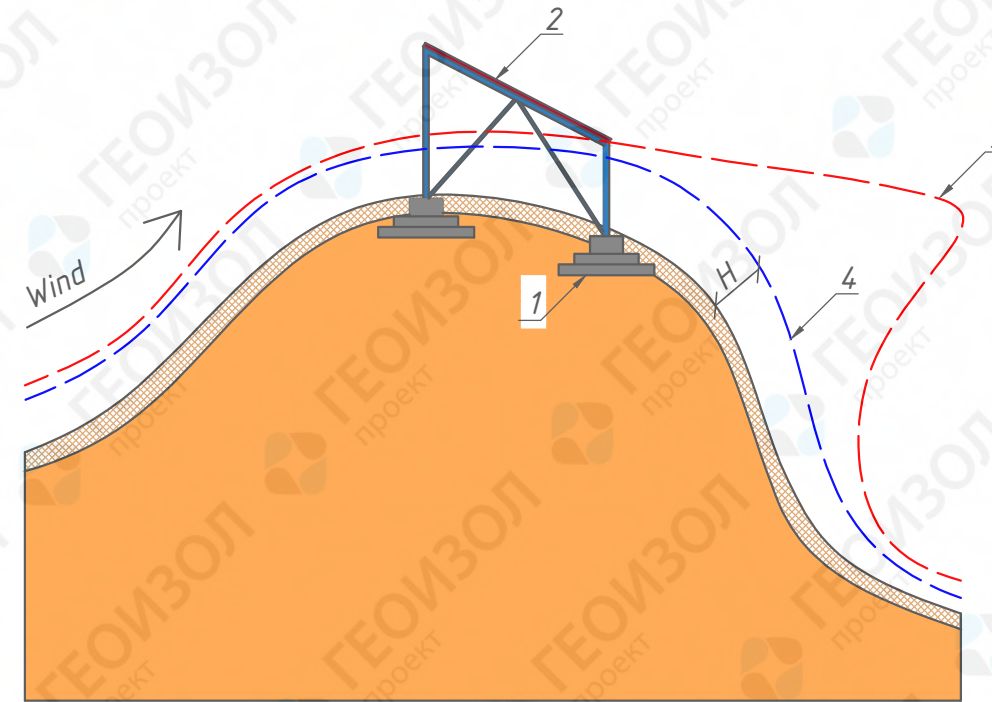

H - Design data of snow cover depth

Examples of the existing objects



№	Nomination
1	Shallow foundation
2	Snow blowing construction
3	Supposititious snow cornice border
4	Snow cover border after installation of the snow blowing construction

Purpose:

- To prevent snow cornice above construction sites.

Operation concept:

Shallow foundation is designed in compliance with the project. The snow blowing construction consists of a metal frame with inclined roof coating. Special aerodynamic shape of the blowing directs the wind streams downwards to the surface of the ground and does not allow the snow masses to accumulate into a cornice.

Unique features of the standard design solution:

- Allows to direct air flows.

Standard design solutions for engineering protection	
Section 7	Avalanche protection
Subsection 4	Snow blowing constructions



Section 8
Bank stabilization

General view

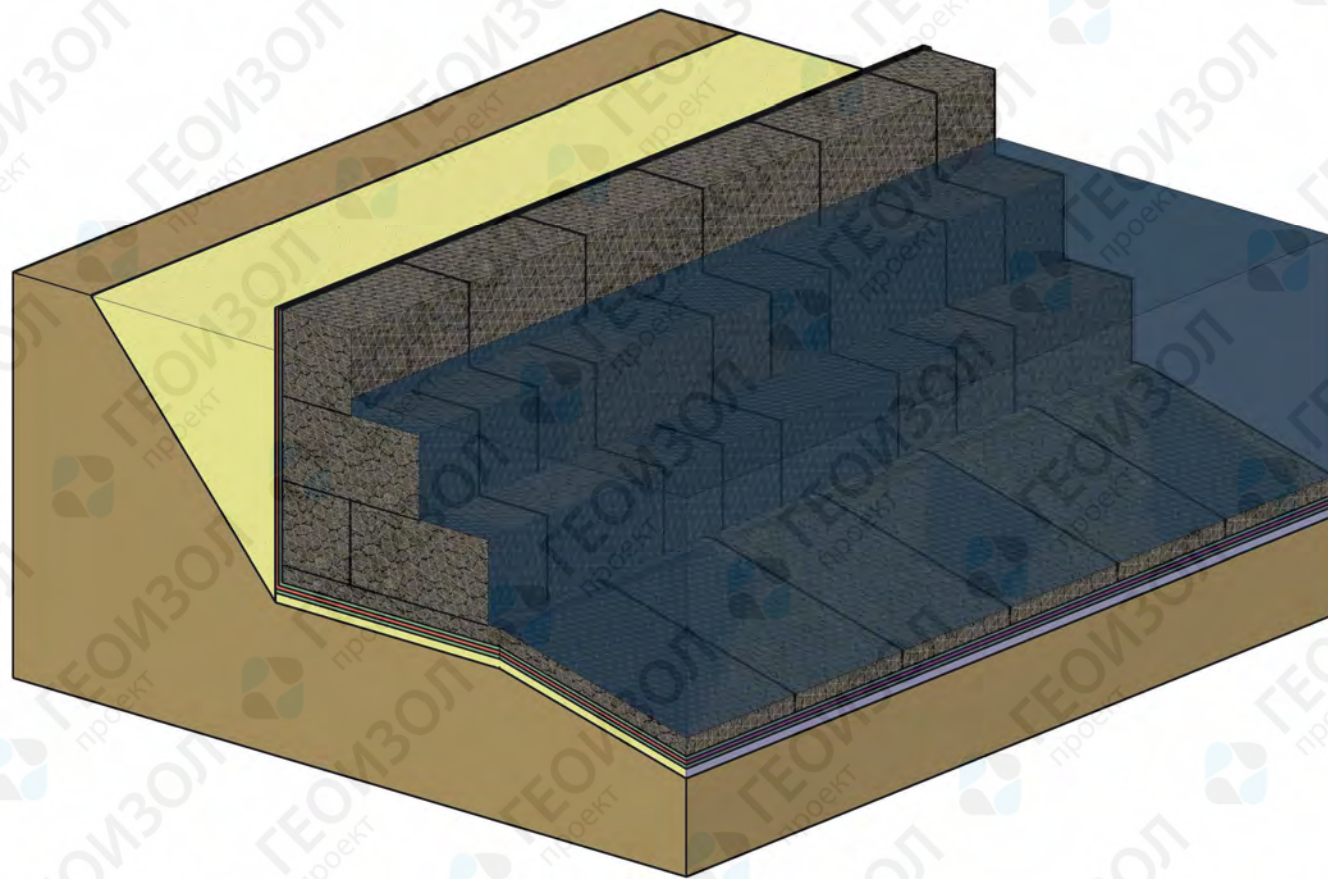

Sectional view

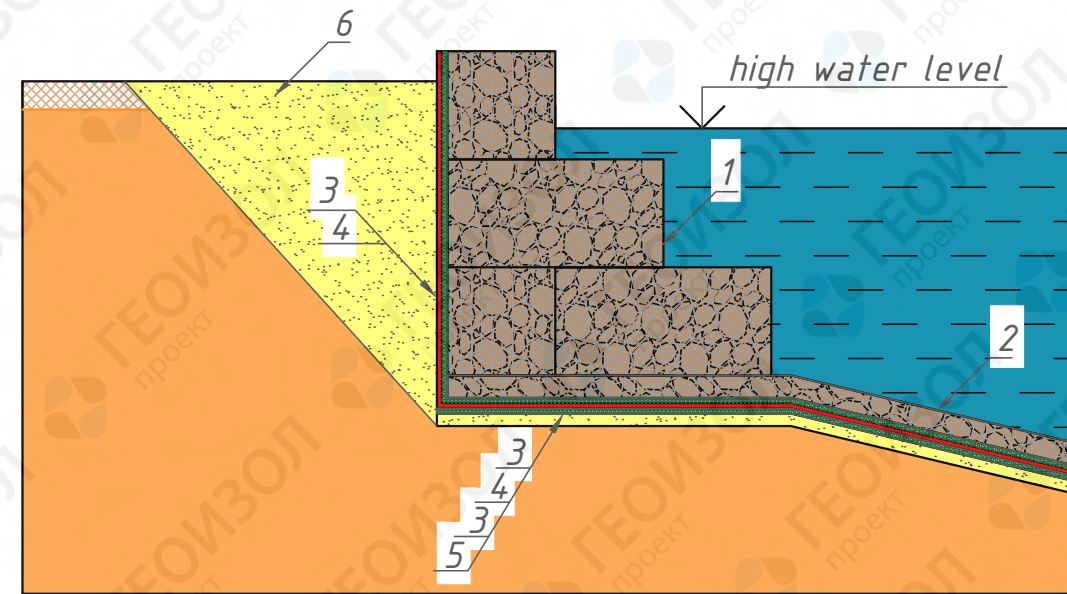

Nº	Nomination
1	Box-shaped gabions construction
2	Mattress gabion
3	Drainage composite material
4	Geomembrane
5	Sand bed
6	Backfill

Examples of the existing objects



Purpose:

- Engineering impoundments;
- To prevent banks erosion.

Operation concept:

A pit sized as the planned impoundment is dug. The bottom of the reservoir is leveled by a layer of sand mattress. Drainage composite material facilitates ground water movement protecting geomembrane from damages. Waterproof material of the geomembrane keeps water level constant, mattress gabions are settled to the bottom of the reservoir to surcharge the geomembrane and drainage composite material. The banks of the impoundment is strengthened by gabion structures to prevent waves impact.

Unique features of the standard design solution:

- Aesthetically and architecturally balanced type of the ready object;
- Simple technology of the works.

Standard design solutions for engineering protection		
Section 8	Bank stabilization	
Subsection 1	Bank stabilization of impoundments	

General view

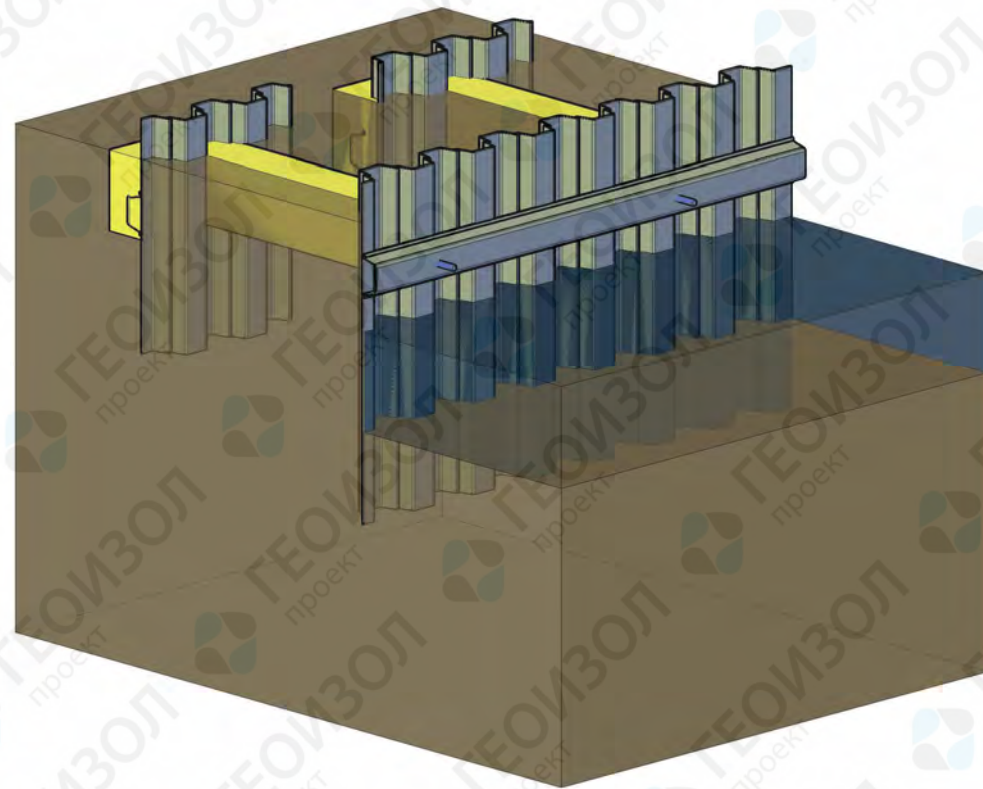

Sectional view

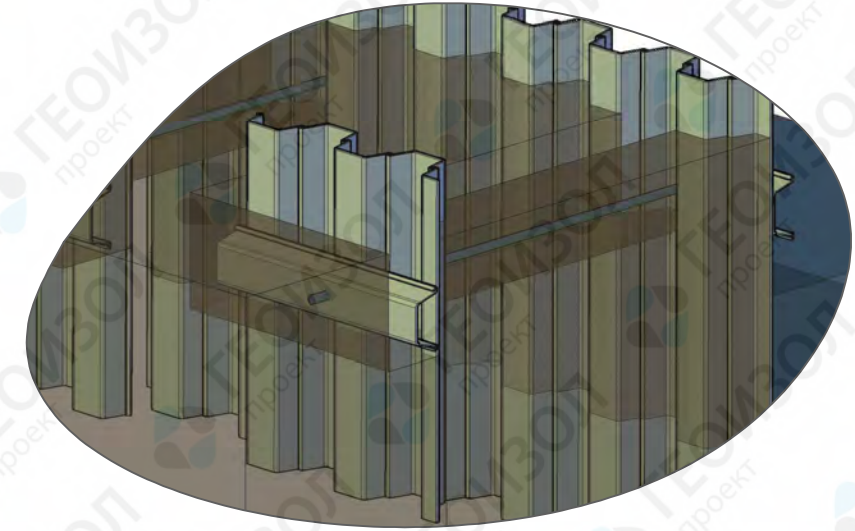
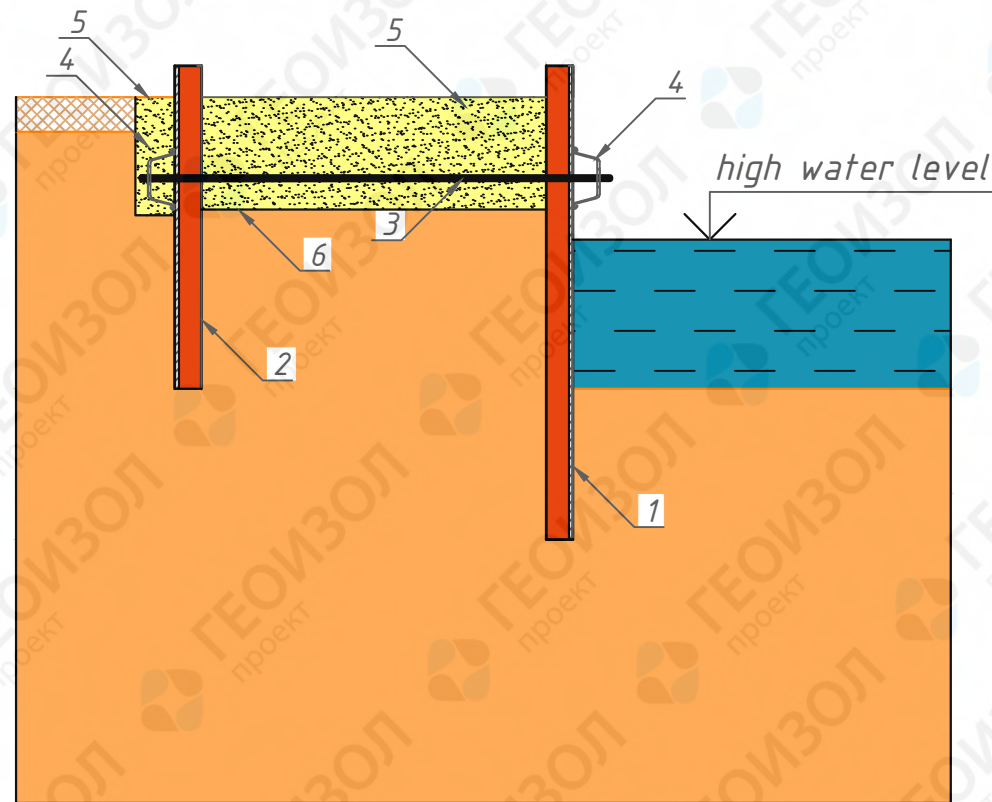

№	Nomination
1	Sheet piling
2	Anchor construction
3	Rod
4	Waling beam
5	Soil backfill
6	Temporary trench for the rod installation

Examples of the existing objects



Purpose:

- To stabilize banks on exposure to waves.

Operation concept:

Sheet piling is installed on the impoundment bank. Anchoring constructions are installed at a distance from the sheet piling. The pressure of the soil onto the sheet piling is transmitted to the anchoring construction via rods and waling beam. In order to install the anchor rods temporary trenches are dug. The second row of the sheet piling increases bearing capacity and reduces movements of the bank piles.

Unique features of the standard design solution:

- Simple technology of the works;
- Allows multiple use of the elements;
- Allows sheet piling construction in short time.

Standard design solutions for engineering protection

Section 8	Bank stabilization
Subsection 2	Sheet piling wall

General view



Sectional view

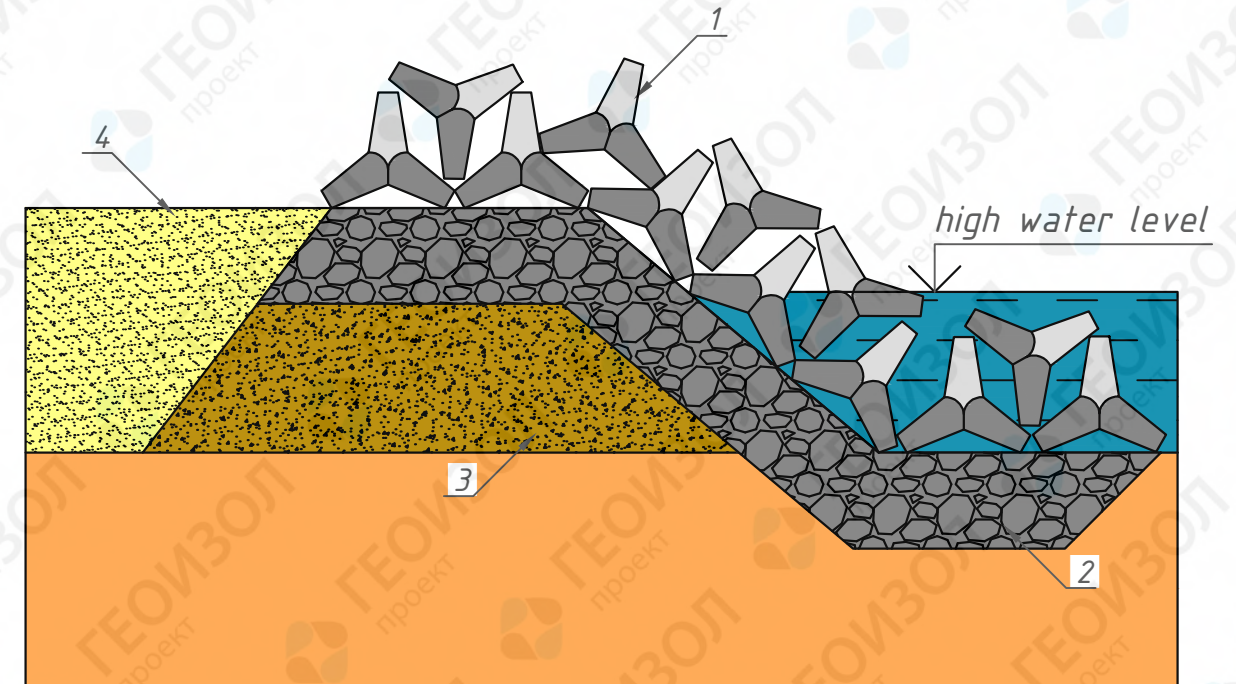

№	Nomination
1	Tetrapod
2	Stone bedding
3	Reversed filter
4	Soil backfill

Examples of the existing objects



Purpose:

- To stabilize banks on exposure to waves.

Operation concept:

The basement of the wave absorber is constructed of a reversed filter and a stone bedding. The reversed filter consists of firm drainage soil, and the stone bedding consists of medium fraction rocky soil. tetrapods are laid on the stone bedding according to the project. Position of every the tetrapod influences absorbing the energy of the waves. A moving wave broken against facets of the tetrapod loses its homogeneity. As the facets consecutively follow the bank slope, the wave gradually loses all the energy.

Unique features of the standard design solution:

- Simple technology of the works;

Standard design solutions for engineering protection

Section 8	Bank stabilization
Subsection 3	Flexible wave canceling structure

General view

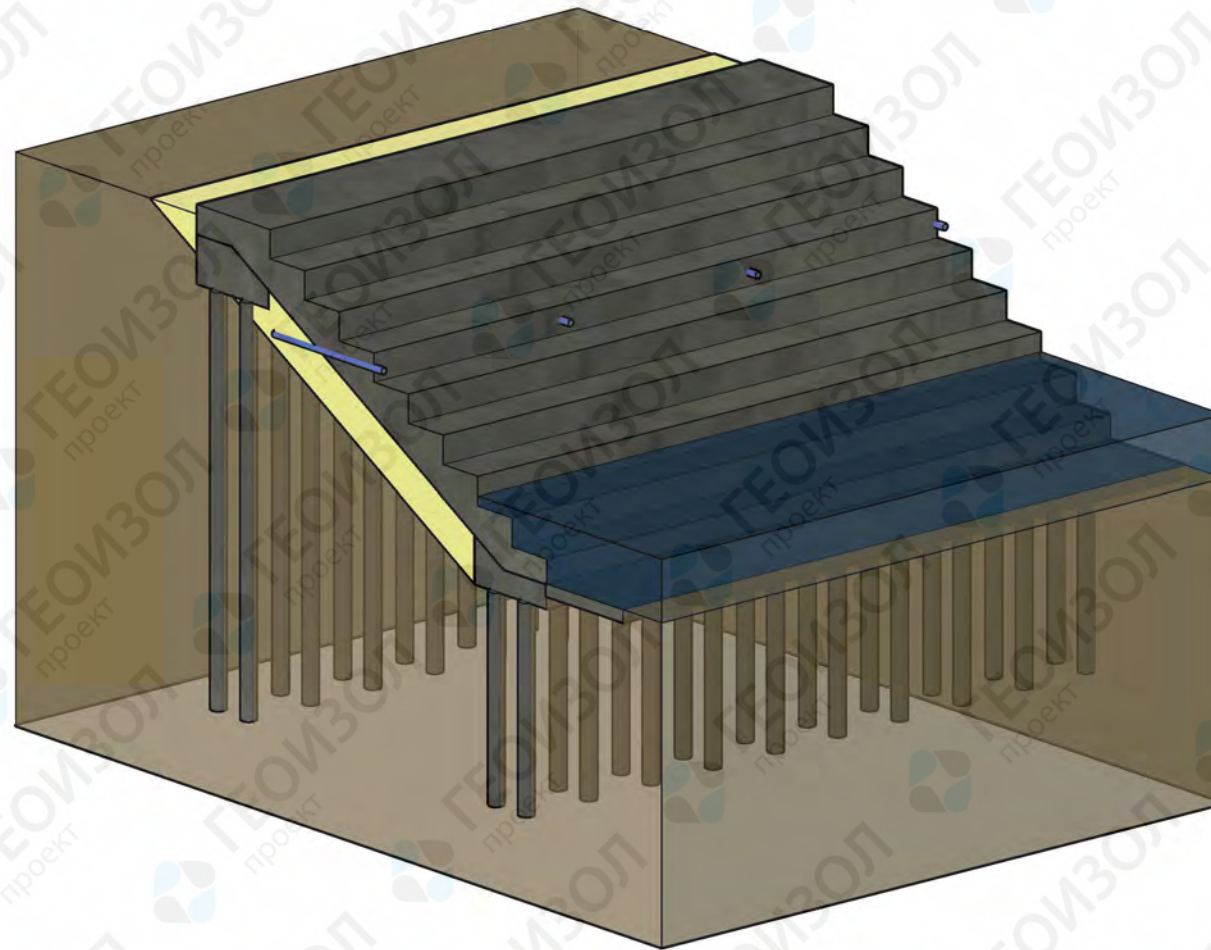

Sectional view

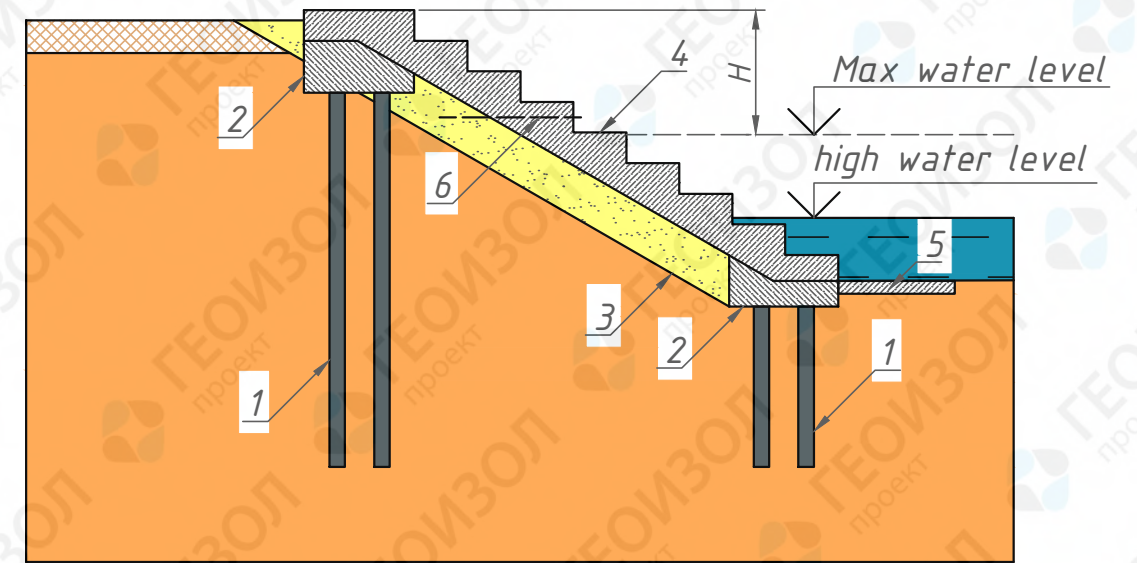

H - Swash height

№	Nomination
1	Piles
2	Piled grillage
3	Soil backfill
4	Stair-type construction
5	Bottom strengthening before construction
6	Drainage system

Examples of the existing objects



Purpose:

- To stabilize banks on exposure to waves.

Operation concept:

Piled foundation of the wave absorber is installed. An armored concrete stair-type construction is installed on the piled grillage. Soil backfill provides filtration of ground waters. Drainage system removes excess of moisture from under the construction and reduces hydrostatical pressure. A moving wave broken against the construction immediately loses its energy. Solid structure prevents removal of the bank ground's particles.

Unique features of the standard design solution:

- Strength and high resistance to waves impact;
- Possible to use as an access to the water;
- Aesthetically and architecturally balanced type of the ready object.

Standard design solutions for engineering protection	
Section 8	Bank stabilization
Subsection 4	Rigid wave canceling structure



Section 9
Protecting of the utilities system

General view

Sectional view

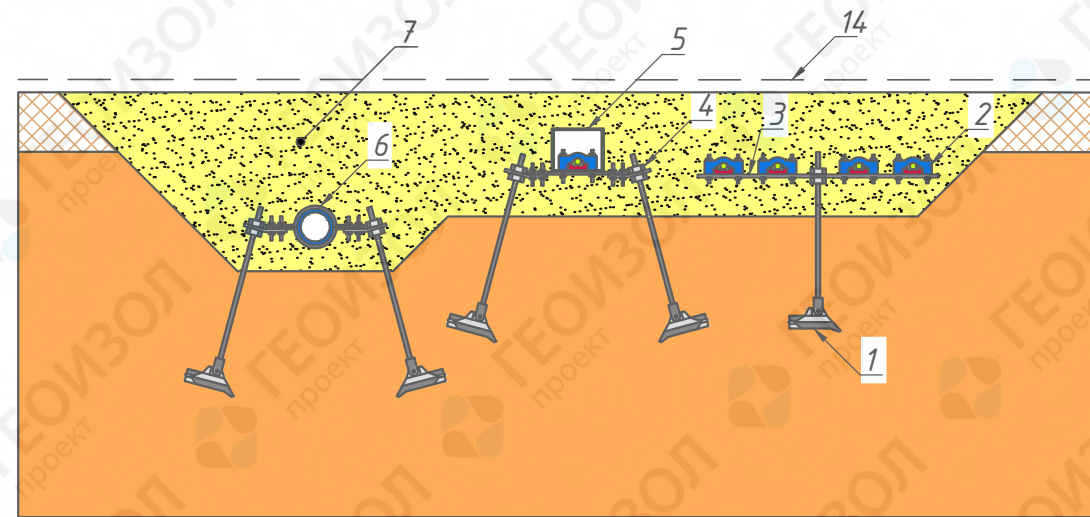
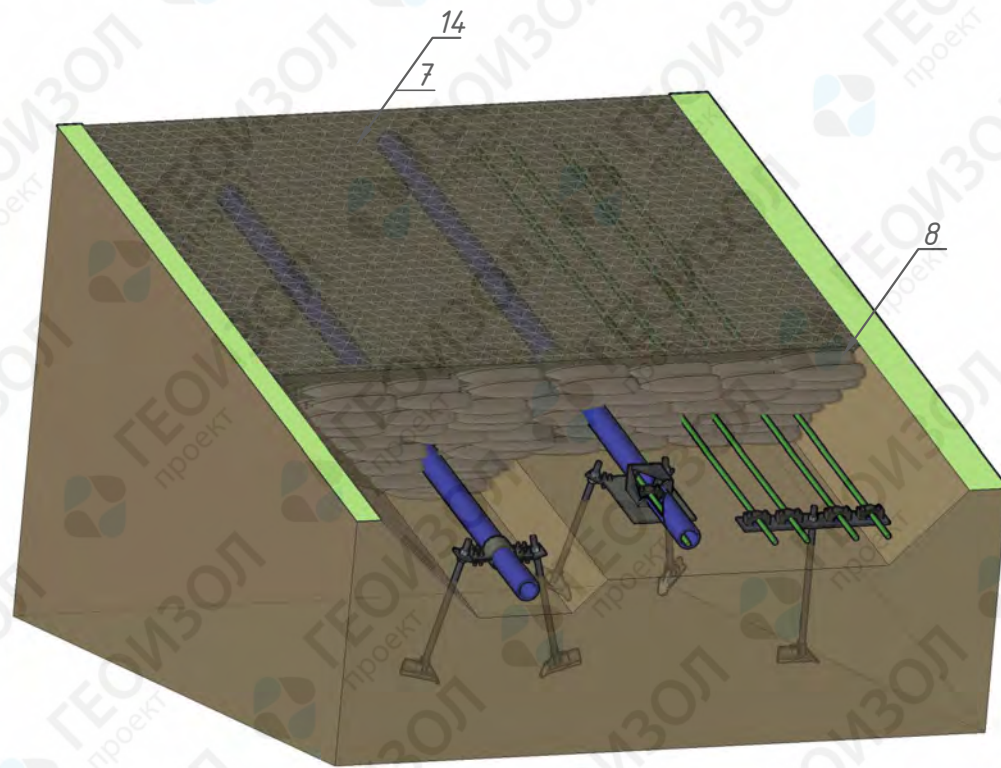

№	Nomination
1	Ground anchoring rod
2	Cable clip
3	Plate with installed clips
4	Nut
5	Isolated junction box
6	Pipe hanger
7	Backfill*
8	Bags with local soil
9	Plate with the installed junction box
10	Cable
11	Attachment of the ground anchoring rod
12	Pipe
13	Pipe sleeve
14	Backfill erosion protection*

* According to the project of laying networks

Fastening of pipes

Fastening of cables

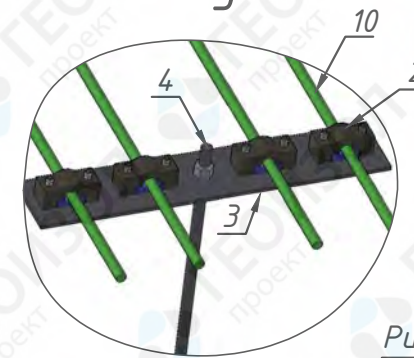
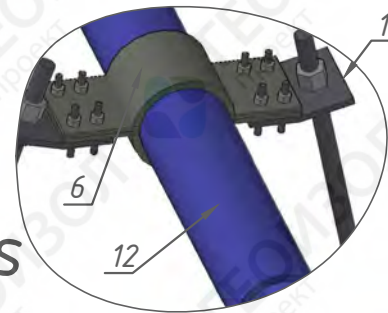

Examples of the existing objects



Fastening of cables laid in a case

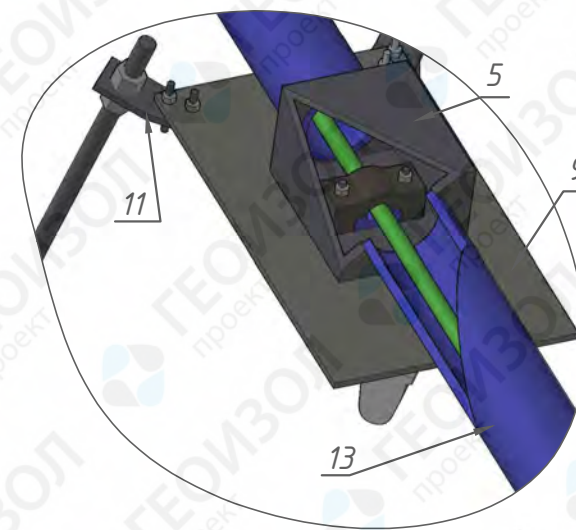

Purpose:

- To protect utilities system on exposure to geological factors.

Operation concept:

A trench for the utility systems is dug. The type of isolation and attachment is chosen according to the type of a utility system. Ground anchors are used to prevent design deviations of the utility systems position. The installed anchors prevent any movements of the utility systems influenced by soil processes. As the trench interferes into the natural properties of the soil, the backfill exposed to water can slide down by gravity. In order to prevent the movements of the saturated backfill dams constructed from bags with local soil are installed across the trench.

Unique features of the standard design solution:

- Embedding utility systems into the slope;
- Allows additional erosion mitigation measures;
- Further re-vegetation is possible.

Standard design solutions for engineering protection

Section 9	Protecting of the utilities system	
Subsection 1	Protecting of the utilities system	



GEOIZOL Group is the leader of Russian building industry in engineering, construction and restoration sector. The origin of the company dates back to 1995. Today GEOIZOL is a multi-specialized incorporating engineering and construction companies, machine building plant and mechanization department.

More than 1500 staff members are employed by the group of companies.



Construction of underground and transport objects, reconstruction of cultural heritage sites, engineering protection of territories, geotechnical and hydraulic engineering works, complex services of building structural survey, geotechnical monitoring, static and plate loading soil tests.

Krummelhaus Business Center 12, Bolshaya Posadskaya Ul., St.Petersburg, Russia, 197046

Tel: +7 812 337 53 13, Fax: +7 812 337 53 10 E-mail: info@geoizol.ru

www.geoizol.ru



Wide range of design services: engineering protection of territories, of all types of foundations, geotechnical feasibility of constructions and design of retaining wall and evaluation of the impact of new construction.

Krummelhaus Business Center 12, Bolshaya Posadskaya Ul., St.Petersburg, Russia, 197046

Tel: +7 812 416 30 28, E-mail: geoizolproject@geoizol.ru

geoizolproject.ru



Pushkin Machine Building plant

Manufacture and supplies of GEOIZOL-MP anchoring systems, drilling machinery, mechanical units, construction metal structures, metal structures for marine and general application

117, Novoderevenskaya Ul., Pushkin, St.Petersburg, Russia, 196600

Tel: +7 812 640 79 95, Fax: +7 812 470 19 51 E-mail: ipmz@geoizol.ru

www.pmzspb.ru



Waterproofing subsurfaces of buildings and structures under construction and at the operational stage. Krummelhaus Business Center 12, Bolshaya Posadskaya Ul., St.Petersburg, Russia, 197046

Tel: +7 812 337 53 16 Fax: +7 812 337 53 10 E-mail: ipgs@geoizol.ru

www.geoizol.ru



Construction machinery and special equipment.

17, Novoderevenskaya Ul., Pushkin, St.Petersburg, Russia, 196600

Tel: +7 812 640 79 93, E-mail: [ium@geoizol.ru](mailto:iум@geoizol.ru)

www.pmzspb.ru